

Student Name _____

Instructor Name _____

Date: ___/___/___

8700 Line Avenue,
 Shreveport, LA 71106
 844-724-CARE (2273)
 Email: service@frymaster.com
 Web sites: www.frymaster.com
www.kitchenware.com
 © Welbilt Foodservice 2019

2019 Edition



8 1 9 7 4 9 9

1/2/2019

Using the Interactive Features in this Manual

Interactive features are embedded throughout this manual. The availability of the feature is based on the form of the book: electronic books have linked video and documents; paper copies have QR codes, linking to Web-posted material.

You will see images (like the non-linked examples above) labeled Video Content. Click on the desired image while viewing on an internet-connected device and the video will play.

The paper manual has QR codes. Service and Parts manuals are linked to their chapters via the codes. The title next to the QR code is hyper linked in electronically published copies of this manual. Click on the title adjacent to the QR code while viewing the manual on a connected device and you will be taken to the desired technical manual.

The Technical Reference Manual and the library of essential Frymaster service and parts manuals are published on the flash drive provided in the training class.

Navigate the Frymaster content of the flash drive (right) by clicking the .html extension after opening the Frymaster folder.

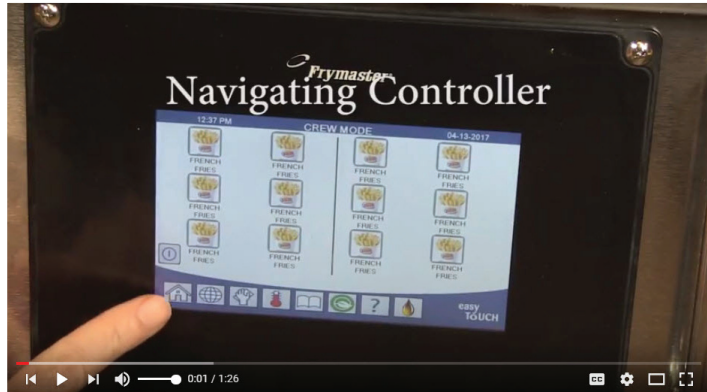

Click the title (mockup above) in an electronic version of this book to open the Major Component Manual from an internet-connected computer. Scan the QR code at left to open the manual on a tablet or smart phone. Videos are embedded in the electronic version of this manual (mockup above).



Artwork	8/22/2018 11:56 A...	File folder	
Computers	8/22/2018 11:03 A...	File folder	
Cover Art	1/9/2018 8:19 AM	File folder	
Forms	1/9/2018 8:17 AM	File folder	
FQ4000 Handout	10/4/2018 2:41 PM	File folder	
Frymaster pdf PowerPoints	8/16/2018 2:19 PM	File folder	
Interactive Tech Reference Level II	12/7/2017 3:22 PM	File folder	
Interactive Tech Reference Level III	12/6/2017 3:14 PM	File folder	
Major Components Manual	1/8/2018 4:47 PM	File folder	
McDonalds Specific	12/6/2017 3:14 PM	File folder	
Read me images	12/6/2017 3:14 PM	File folder	
Service Manuals	12/6/2017 3:14 PM	File folder	
TouchscreenFQ4000_TB Training 8-23-18	12/6/2018 2:43 PM	File folder	
Training Modules	8/16/2018 2:44 PM	File folder	
Autorun.inf	3/26/2015 2:50 PM	Setup Information	1 KB
complete_technical6_library.html	8/22/2018 3:06 PM	HTML Document	31 KB
PTStart.exe	2/25/2001 11:35 PM	Application	48 KB
Read_Me.pdf	7/7/2015 2:51 PM	Adobe Acrobat D...	169 KB

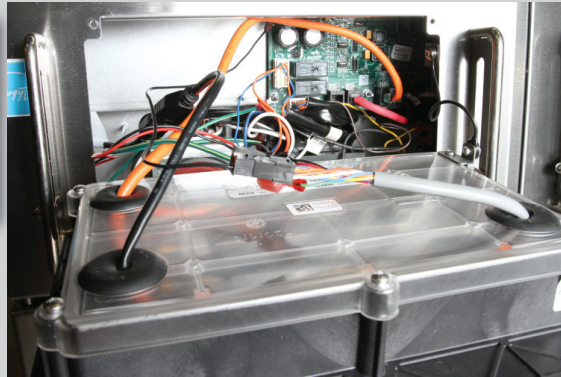
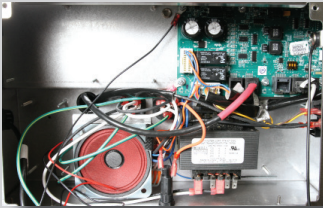
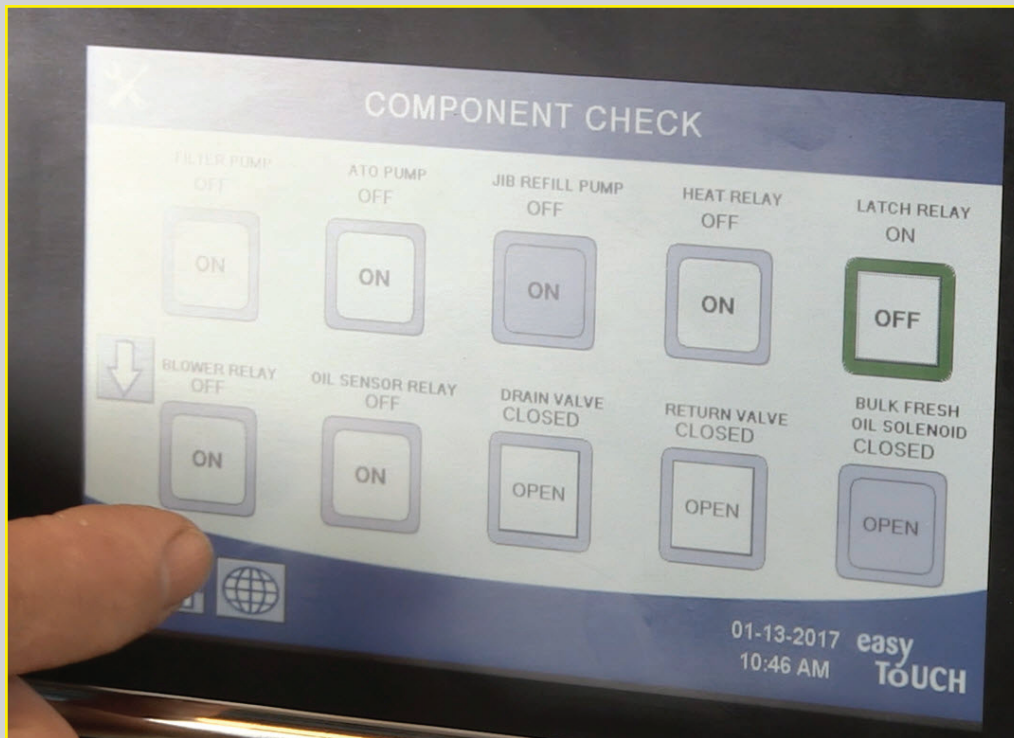

Level III Tech Reference

Table of Contents

Automatic Filtering Fryers	1-1
Oil Conserving Fryers	2-1
FilterQuick Touch Fryers	3-1
Codes/Charts/Tables	4-1

Chapter 1: Automatic Filtering Fryers

McDonald's LOV

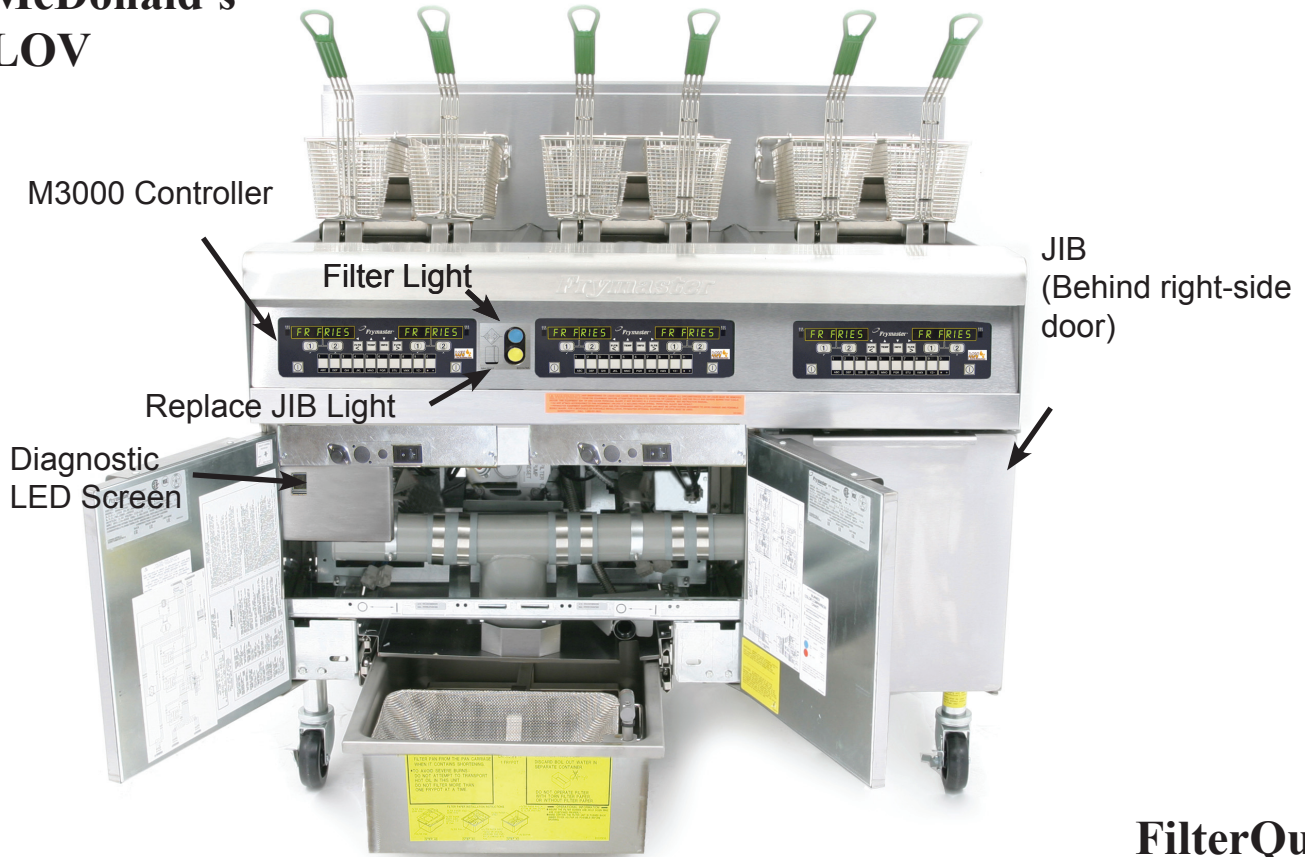

FilterQuick

Features

- **Low volume frypot (LOV)** — 30 pounds rather than 50 pounds of oil.
- **Automatic top-off (ATO)** — Automatically maintains an optimal oil level with a reservoir in the cabinet.
- **CAN** — Controller Area Network
- **Manual Interface Board (MIB)** — Controls the filtration and top off system.
- **Automatic Intermittent Filtration Board (AIF)** — Controls the actuators.
- **Automatic filtration** — Performs hands-free filtering at prescribed cook cycle counts or at prescribed times.
- **Oil savings** — The combination of a low-volume fry vat and oil automatically kept at a optimal level, reducing oil usage.



Automatic Filtering Fryers

Online Access to Automatic Filtering Fryer Manuals



LOV Gas Service



LOV Gas Parts

Scan these QR codes to access the required service manual.



LOV Electric Service



LOV Electric Parts



LOV Electric Diagrams



FilterQuick Electric Service



FilterQuick Electric Parts



FilterQuick Electric Wiring Diagrams



FilterQuick Gas Service



FilterQuick Gas Parts

Automatic Filtering Fryers

The auto filtering fryers are built on a 30lb frypot platform, which dials in a 40 percent reduction in oil to fill each pot. Both fryer systems produce savings in oil with low-volume vats and the management of optimal oil levels.

The fryers also feature:

- Automatic filtering.
- Automatic top off.

The automatic filtering fryers get special attention at start up and time is allotted for training store staff on operation. Two hours per system is provided for start up and an additional two hours for training the staff.

Among the items that need stressing is response to the filter requests, frequent changing of the filter paper or pad, keeping the filter pan free of debris and, on gas fryers, the frequent cleaning of the Oil Is Back, or OIB, sensor.

The fryers monitor the length of time required for oil to return to the frypot after a filter cycle and interpret sluggish return times as a problem in the filter pan.

These fryers are available in a McDonald's-exclusive configuration and also a general market version. The fryers share a lot of similarities, including circuit boards that monitor the automated systems and a Controller Area Network (CAN) that carries the communication in the system. Although similar, the boards and their software are not interchangeable across the platforms.

Here are features both platforms share:

- A manual interface board, or MIB, monitors the oil filtration and top off.
- An automatic top off board, or ATO, works with the MIB to direct oil to a frypot low on oil.
- An automatic intermittent filter board, or AIF, operates actuators, opening and closing valves during an automatic filter cycle.
- A Controller Area Network (CAN) communication system.
- A JIB, or jug in a box, is positioned in the cabinet to provide oil to the top off system. The level of the JIB is also monitored by the fryer's control system.

Both fryer systems produce savings in oil with the use of the low-volume oil vats and the management of optimal oil levels. The systems differ in the operation of the automatic filter system.

The McDonald's unit signals the need for filtration with a blue LED on the bezel and a prompt from the M3000 controller. Responding Yes to the prompt with a key on the controller launches the filter cycle.

The FilterQuick signals the need for a filter with a blue LED-encircled button and a prompt on the FilterQuick 3000 controller. Pushing the button opens the drain, the first step in the filter cycle.

Automatic Filtering Fryers

Data Network Flow Chart

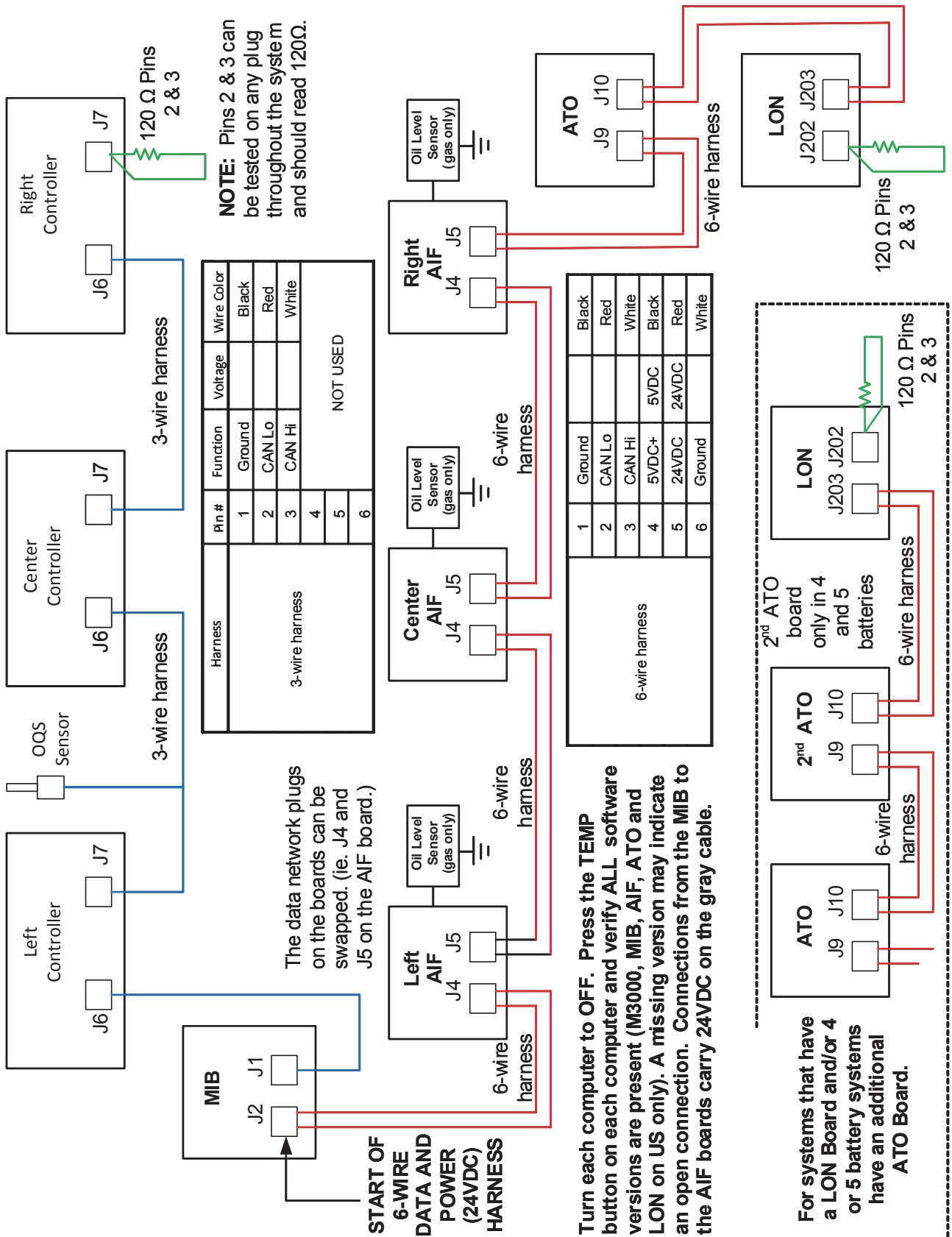

Automatic Filtering Fryers

Auto Top Off System

The core of the system is the automatic top-off board. It senses when the oil is low and fills the pot to the top line.

The oil level is monitored by an RTD (Resistance Temperature Detector) sensor in the frypot at the upper oil level. The oil is pumped to the pot from a reservoir, called a JIB (Jug In Box).

A circuit board, the ATO (Automatic Top Off), is located inside a box behind the JIB. It monitors the oil-level RTD and activates the pump when it senses an oil temperature drop of 60°F below setpoint, indicating the oil has moved away from the sensor. The ATO sends a signal to the MIB (Manual Interface Board), which then sends a signal to the AIF to open the actuator on the return valve of the frypot to be topped off.

Once the actuator has opened the return valve, oil is pumped into the vat for approximately 60 seconds. When the ATO RTD detects a temperature within 55°F of setpoint, it is satisfied and the actuator closes the valve. Top off will continue on the next vat if needed.

The system is not active until the oil reaches setpoint. That temperature is monitored by the temperature probe. The activation of the system is handled by the fryer's controller. The automatic top off system is also inactive during filter and dispose cycles.

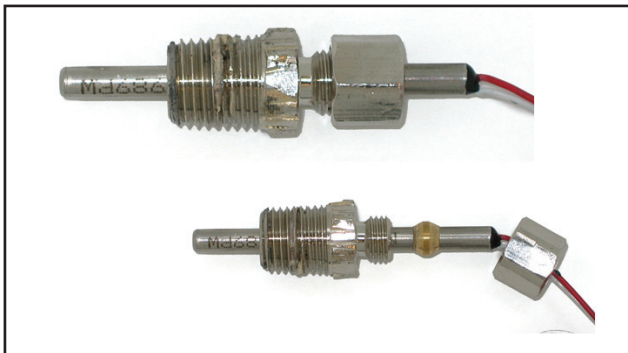
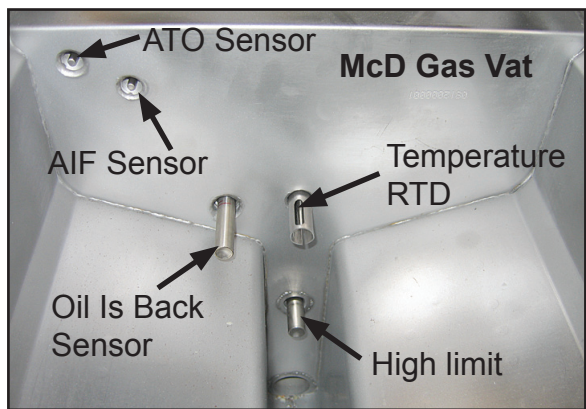
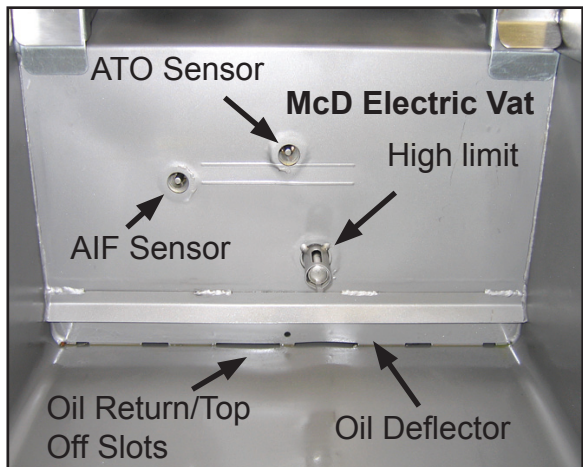

The ATO RTD (bottom in picture above) used in auto filtering fryers is similar to the probe used in the H55 (top) and has the same resistance scale. However, it is not interchangeable; it's much smaller. The low-volume frypot probe uses a nut and ferrule.



An Automatic Top Off Board, or ATO, (see arrow) monitors frypot oil levels and opens valves and runs a top-off pump to move oil from a JIB to the low frypot. The ATO board is housed behind the JIB along with transformers and a relay related to the top-off system. The McDonald's box may hold a LON board (eliminated in December 2014), a device for internal controller-based monitoring of the complete fryer system. The vats (above) are equipped with ATO sensors to monitor oil levels.

Automatic Filtering Fryers



A JIB (Jug in a Box) is shown being placed in a fryer cabinet.



A 24-volt pump moves the oil from the JIB to the frypots. The pump is accessible from the rear of the fryer. It is mounted vertically or horizontally, depending on the space available in the fryer cabinet.

Testing ATO RTD Probes

The FilterQuick 3000 controller has a quick way to compare the resistance value of the ATO RTD to the vat temperature. This is a handy diagnostic tool. With the controller OFF, press and hold the TEMP button. The controller will display AIF and current temperature followed by ATO and current temperature. Compare the resistance of the probe against the controller's temperature reading, using the chart on page 4-8 and 4-9. If the values differ greatly, a harness issue may exist. This diagnostic feature is available on FilterQuick and OCF fryers. It's not on LOV fryers.

Troubleshooting the Top Off System

Problem	Probable Causes	Corrective Action
Frypot tops off cold.	Incorrect setpoint.	Ensure setpoint is correct.
No power to ATO board.	A. J5 connection unplugged. B. Fuse blown. C. Transformer malfunction.	A. Check to ensure J5 on front of ATO board is fully locked into connector. B. Ensure fuse below right control box (McD); right side of ATO box (FQF) is not blown. C. Check that proper voltage is present at transformer. See charts on pages 1-53.
The yellow JIB low light (McD platform only) won't illuminate.	A. Loose wire connection. B. Power in the component box is not present. C. Failed transformer.	A. Ensure the yellow LED is securely attached to plug J6 on the ATO board. B. Ensure power is present in the component box. C. If power is present in component box, check the transformer for correct voltage.

Automatic Filtering Fryers

Problem	Probable Causes	Corrective Action
Frypots won't top off.	<ul style="list-style-type: none"> A. Probe temperature lower than setpoint. B. Oil is too cold. C. Bad connection. D. ATO board power loss. E. Failed transformer/harness. F. ATO pump failed. G. Failed ATO board. H. ATO pump/lines plugged I. Empty JIB 	<ul style="list-style-type: none"> A. Fryer temperature must be at setpoint. Check ATO probe resistance. If probe is bad, replace the probe. B. Ensure that the oil in the JIB is above 70°F (21°C). C. With the controller OFF, press TEMP button and ensure the ATO version appears. If not, the connection between the AIF and the ATO board may be bad. Ensure the 6-pin CAN connectors are tight between AIF (J4 and J5) and ATO (J10) boards. D. Power to the ATO board has been cut off. Restore power to the board and clear any service-required errors. E. Check power from transformer to ATO board. Ensure all harnesses are plugged securely into place. F. Check voltage to pump. Replace the pump if defective. G. Check for proper voltages using the pin-position charts found on pages 1-53 — 1-56. If ATO found defective, replace ATO board and clear any errors. H. Clear pump/lines. I. Ensure JIB has oil.
One vat tops off but other vats fail to top off.	<ul style="list-style-type: none"> A. Loose wire connection. B. Actuator issue. 	<ul style="list-style-type: none"> A. Ensure all wiring harnesses are securely connected to ATO board and solenoids. B. Check return actuator to ensure actuator is functional.
Incorrect vat tops off.	<ul style="list-style-type: none"> A. Wired incorrectly. B. Flexlines connected to wrong vat. 	<ul style="list-style-type: none"> A. Check wiring. B. Switch flexlines to correct vat.
One vat doesn't top off.	<ul style="list-style-type: none"> A. Filter error exists. B. Actuator, pump, loose connection, RTD or ATO issue. 	<ul style="list-style-type: none"> A. Clear filter error properly. When CHANGE FILTER PAD (or paper) YES/NO is displayed, do NOT press any button until the pan has been removed for at least thirty seconds. After thirty seconds have elapsed, the controller returns to OFF or last display. B. Check actuator, ATO pump, wire connections, RTD and ATO board.

Automatic Filtering Fryers

Auto Filtration (MIB and AIF)

The auto filtration system is controlled by the fryer’s controller, the AIF (Automatic Intermittent Filtration) board and the MIB (Manual Interface Board). The filtration is largely hands-off. A button push starts the operation.

Actuators — linear on the early McDonald’s fryers and rotary on FilterQuicks and later McDonald’s units — operate the valves.

The controller is programmable and it allows filter cycles to be launched after a set number of cook cycles and a prescribed elapsed time.

The system can be set to lock out automatic filtration during busy times, such as the lunch rush.

The operator can decline a filter; cooking can continue. When an automatic filter cycle is launched, the MIB and the AIF boards communicate. The MIB controls and oversees the filtration; the AIF board operates the actuators, which open and close the valves.

The MIB is in the fryer cabinet. It is partially covered by a sheet metal cover and the LED display is visible. Buttons behind the cover allow limited manual operation.

The LED displays codes that can be used to diagnose failures.

The controllers (FilterQuick above left and M3000 above right) scroll a request to filter when the fryer vat reaches a pre-programmed number of cook cycles. The McDonald’s fryer (above) flashes a large blue LED on the bezel. The FilterQuick illuminates (right above) a button below the controller.

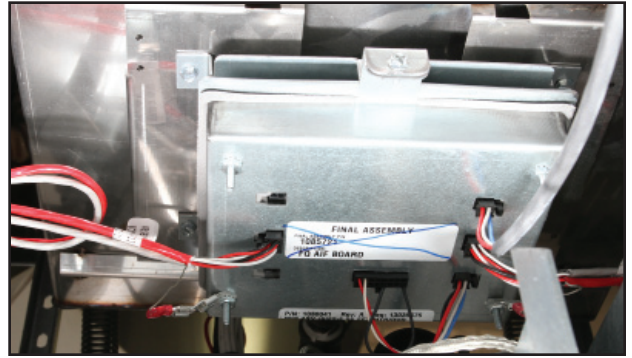

An AIF board is mounted under each fry vat.



Video Content
Click to Play FilterQuick (left) McDonald’s (right)

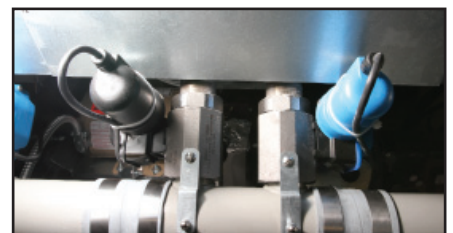
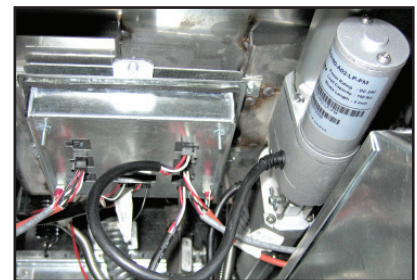
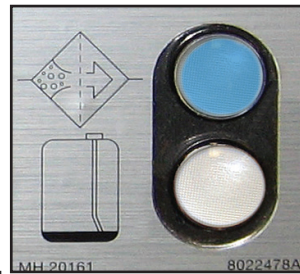
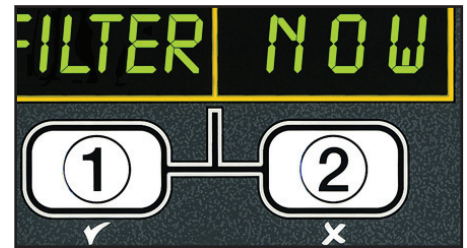

Valve actuators were initially linear (above right) on the LOV fryers. Rotary actuators (right) became the standard on the electric model in January of 2012 and on the gas in May of that year. Linear and rotary are not interchangeable.

Automatic Filtering Fryers

Mode Display

Shows status (auto or manual) vat number (when operating valves manually) and displays error codes.

Vat Selection

Selects vat for manual operation of valves.

Manual/Auto

Switches fryer from auto to manual operation.

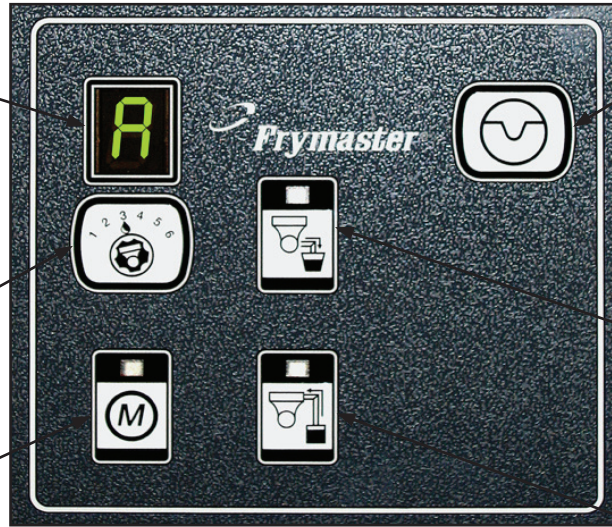

The MIB board.

Reset

Short press -resets system, ensures all valves are closed. Long press - (15 sec) resets MIB board and clears all errors.

Drain

Opens and closes drain valves in manual mode.

Return

Opens and closes return valves and turns on filter pump in manual mode.

Error Codes

The mode display on the face of the MIB board displays a range of letters, which indicate activity or an error. (See below.)

1L, 1r - 5L, 5r — Numbers correspond to vats: “L” indicates the left side of a split vat. “r” indicates a full vat or the right side of a split vat.

A — **Auto mode:** auto filtration enabled.

P — **Pan switch:** filter pan is not in place or not sensed. Auto Filtration disabled.

r — **Reset:** r alternating with a vat number indicates that the MIB board is resetting. If r is displayed without alternating with a vat number, a problem may exist with the MIB board itself.



The MIB is mounted behind the left door on automatic fryers. See arrow.

Automatic Filtering Fryers

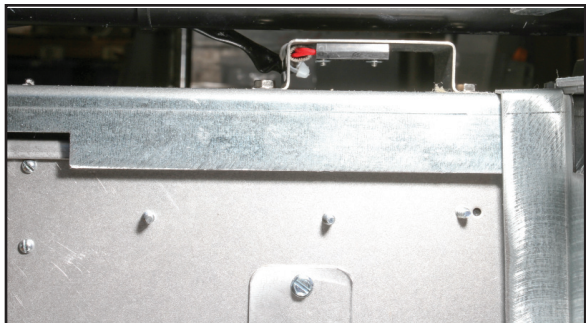

Detecting the Filter Pan

The filter pan must be present in the fryer for auto filtering to function. A circuit, closed when the pan is in place by a reed switch in the cabinet interior (left and below) and a magnet on the pan's front edge (circled below), tells the system that the pan is in place. The P, displayed on the MIB, goes away when the pan is detected.

The reed switch is visible in the rear of the filter cabinet (top right) and close-up (right). The button-size magnet is circled on the pan front (below).

The placement of the switch and the magnet has varied over time and auto filtering fryer models.

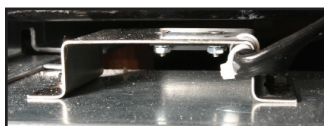

Manual Draining, Filling, Filtering with MIB



1. Press the M button, which switches the board to manual. The display becomes the number of the vat to be controlled manually.
2. Press the vat selector button until the desired vat number is displayed.
3. Press the drain button to drain the oil or press and hold the return button to return oil to the vat displayed. Opening the drain and pressing and holding the return button after valve is open allows filtration.
4. Pressing the M button again returns the board to automatic mode.

Automatic Filtering Fryers

Troubleshooting the Manual Interface Board (MIB)

Problem	Probable Cause	Corrective Action
<p>Auto filtration won't start.</p> <p><small>* McDonald's only</small></p>	<ol style="list-style-type: none"> 1. Filter pan out of position. 2. Oil Level is too low. 3. Ensure MIB board is not in manual mode. 4. Ensure MIB cover is not damaged and pressing against buttons. 5. Filter relay has failed. 6. AIF disable* is set to YES, blue light doesn't light. 7. Filter motor thermal switch is tripped. 8. AIF clock* enabled. 	<ol style="list-style-type: none"> 1. Ensure filter pan is fully inserted into fryer. 2. Ensure oil level is above the oil level sensor. 3. Ensure MIB board is in "A" automatic mode. 4. Remove and replace cover and see if filtration will start. 5. Replace filter relay with part number 807-4482 24VDC relay. 6. Set AIF* disable in Level 1 to NO. 7. Press filter motor thermal switch. 8. Ensure AIF* clock is set to disabled.
<p>MIB display shows something other than an "A" or vat number.</p>	<p>An error has occurred and displayed character indicates error.</p>	<p>See MIB display diagnostics on page 1-9 for explanation.</p>
<p>No power present at the MIB board</p>	<p>Transformer has failed in left component box.</p>	<p>Check output on the left transformer in left component box; should read 24VAC. If not replace transformer.</p>
<p>MIB will not clear error.</p>	<p>Error remains in non-volatile memory.</p>	<p>Press and hold reset button in top right corner for five seconds. The drain, return and manual/auto LED's will illuminate and the MIB will reset and clear any remaining errors from memory. Allow 60 seconds to reset. If an error still exists, there's another issue.</p>
<p>MIB indicates incorrect number of vats.</p>	<ul style="list-style-type: none"> • Network is not terminated correctly. • Wiring harnesses are loose or damaged. • AIF board issue. • Locator pin issue. 	<p>Ensure the CAN bus system is terminated at BOTH ENDS (on the controller connector J6 and on the ATO board connector J9) with a resistor-equipped 6-pin connector.</p> <ul style="list-style-type: none"> • Unplug and reseat all wiring harnesses in CAN system. Resistance between pins 2 and 3 on the CAN network connectors should be 120 ohms. • Check software version numbers on all controllers and ensure all display an AIF version. If an AIF version is missing, the AIF board may be missing power. Check pins 5 and on J4 and J5 of the affected AIF board for proper voltage. • The locator pin in J2 of the AIF board is either loose or in the incorrect position. See the chart on pages 1-55 — 1-59 of this manual for proper pin position.

Automatic Filtering Fryers

Problem	Probable Cause	Corrective Action
<p>MIB board alternating “E” and “vat number and side.”</p>	<p>Network error on the CAN bus communication.</p>	<p>A. Ensure the CAN bus system is terminated at BOTH ENDS (on the controller connector J6; ATO board connector J10) with a resistor-equipped 6-pin connector.</p> <p>B. With the controller OFF, press TEMP button and ensure the AIF version appears. If not, the 24V to the AIF boards may be missing. Ensure all 6-pin CAN connectors are tight between the controller (J6 and J7), MIB (J1 and J2), AIF (J4 and J5) and ATO (J10) boards.</p> <p>C. With the controller OFF, press TEMP button and ensure the ATO version appears. If not, check the CAN wire harness between the AIF board J4 or J5 and the ATO board J9 or J10. The ATO fuse on the right side of the ATO box may be loose or blown; the 110V to the ATO transformer may be missing or bad. The J4/J5 connector may be loose.</p> <p>D. Check if MIB has 24V on pins 5 and 6 of J2. Check to see if 24V is present on pins 5 and 6 of wire harness plugging into J4 or J5 of the first AIF board. If 24V missing, check the pins. Replace the harness if necessary.</p> <p>E. Check continuity between each color wire on the CAN connectors into J7 on the far right controller and J10 on back of the ATO board (black to black, white to white, and red to red) and ensure there is no continuity between different color wires (black to red, red to white, and white to black).</p> <p>F. Ensure black controller locator wires are connected from ground to correct pin position (see pages 1-54 — 1-58).</p> <p>G. Ensure all boards have the corner ground wire attached and tightened.</p> <p>H. Check for loose locator pin or incorrect positioning in J2 of the AIF board. See the charts on pages 1-54 — 1-58 of this manual for proper pin position.</p> <p>I. Bad MIB and/or AIF board.</p> <p>J. Broken resistor lead. Unwrap the resistor leads and check ends.</p>

Automatic Filtering Fryers

Troubleshooting the AIF System (AIF)

Problem	Probable Cause	Fix
Wrong vat opens.	<ol style="list-style-type: none"> 1. Actuator is plugged into wrong connector. 2. Locator pin is in wrong position. 	<ol style="list-style-type: none"> 1. Ensure the actuator is plugged into the correct connection (J1 for FV return, J3 for DV return; J6 for FV drain, J7 for DV drain). 2. Ensure the locator pin is in the proper position in plug J2. (See charts on pages 1-53 — 1-60 of this manual for proper pin position.)
Actuator doesn't function.	<ol style="list-style-type: none"> 1. No power to AIF board. 2. Actuator unplugged. 3. AIF board failure. 4. Actuator readings are out of tolerance. 5. Actuator is bad. 	<ol style="list-style-type: none"> 1. Check pins 5 and 6 of J2 at the MIB board. Should read 24VDC. Check voltage on pins 5 and 6 at the other end of the harness and ensure 24VDC is present. Check pins 5 and 6 for 24VDC on plugs J4 and J5 on AIF boards. 2. Ensure actuator leads are plugged into AIF board (J1 for FV return, J3 for DV return; J6 for FV drain, J7 for DV drain). 3. Check the power on the connector of the problem actuator while manually opening or closing the actuator. Pins 1 (black) and 4 (white) should produce +24VDC when the actuator is opening; -24VDC should be read from Pins 2 (red) and 4 (white) when the actuator is closing. If either voltage is missing, the AIF board is likely bad. Test the actuator by plugging into another connector to open or close. If the actuator operates, replace the board. 4. Check resistance of the potentiometer between pin 3 (purple wire) and pin 4 (gray/white wire). Closed should read 0-560Ω. Open should read 3.8KΩ - 6.6KΩ. 5. If proper voltages are seen at the connector and the actuator doesn't operate, replace the actuator.

Automatic Filtering Fryers

Oil Return Sensor (OIB) Troubleshooting (Gas Only)

The heated oil-return sensor prevents dry firing of the frypot. It's energized with line voltage when the controller is powered on. The sensor is in series with a 7-second time delay board that provides 24VAC to the gas valve. In the absence of oil, the sensor heats to its 570°F setpoint, which sets off a 4-second internal relay to control its temperature. The 4-second cycling of the power disrupts the 7-second delay relay board providing power to the gas valve. The fryer can't heat without oil in the vat.

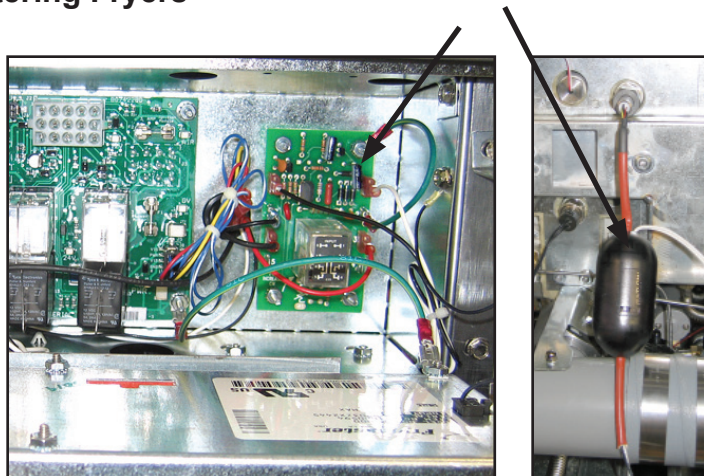

The oil return sensor is controlled by a small board and the electronics inside the egg-shaped device shown above. The board is in the control box; the "egg" is near the probe.

McDonald's Fryer: The 120VAC travels through the basket-lift relay on the interface board and then goes out pin 7 on J1 (DV) or pin 7 on J3 (FV).

FilterQuick: The line voltage that powers the OIB sensor is switched by the OIB relay (12VDC coil).

Typical sensor-related failures:

- Low temp but no call for heat (heat light).
- Stuck in melt cycle with no call for heat.
- Filter error (**IS VAT FULL?**) with oil in the filter pan (no oil in the vat).



Regular cleaning of the Oil is Back sensor is critical. Insulating oil residue affects its operation and oil won't return to the frypot.

If the controller doesn't exit melt cycle or continues to display low temp and does not heat, ensure that the gas supply, gas valve, and other components are working properly. If no heat lamp illuminates because no call for heat is initiated, check for carbon buildup on the OIB sensor.

- Power to oil sensor (from relay used for basket lifts on other interface boards K1(DV) or K4 (FV)). Check pin 7 on J1 (DV) or pin 7 on J3 (FV) for 120VAC.
- Power to heater/relay coil on relay board. Check voltage to the coil on pins 8 and 1 to ensure that 120VAC is present with oil in the vat. If the vat is empty, the power will cycle 4 seconds on, 4 seconds off.
- Check between pin 3 and 2; 5VDC for air and 0VDC for oil. A common message for a shorted harness or issue is **IS DRAIN CLEAR?** with oil in the filter pan.
- Check ground on pin 2 on relay board to stud for a secure ground.
- Check AIF communication harness. Interrupted communication will prevent the fryer from heating.
- If the oil level sensor is cycling 4 sec. on/off and oil is surrounding the sensor and LOW TEMP is displayed, the sensor may have a carbon build up that is insulating the sensor. Use a no-scratch pad to remove carbon build up. Carbon build up on the OIB counts for a large number of customer issues.

Automatic Filtering Fryers

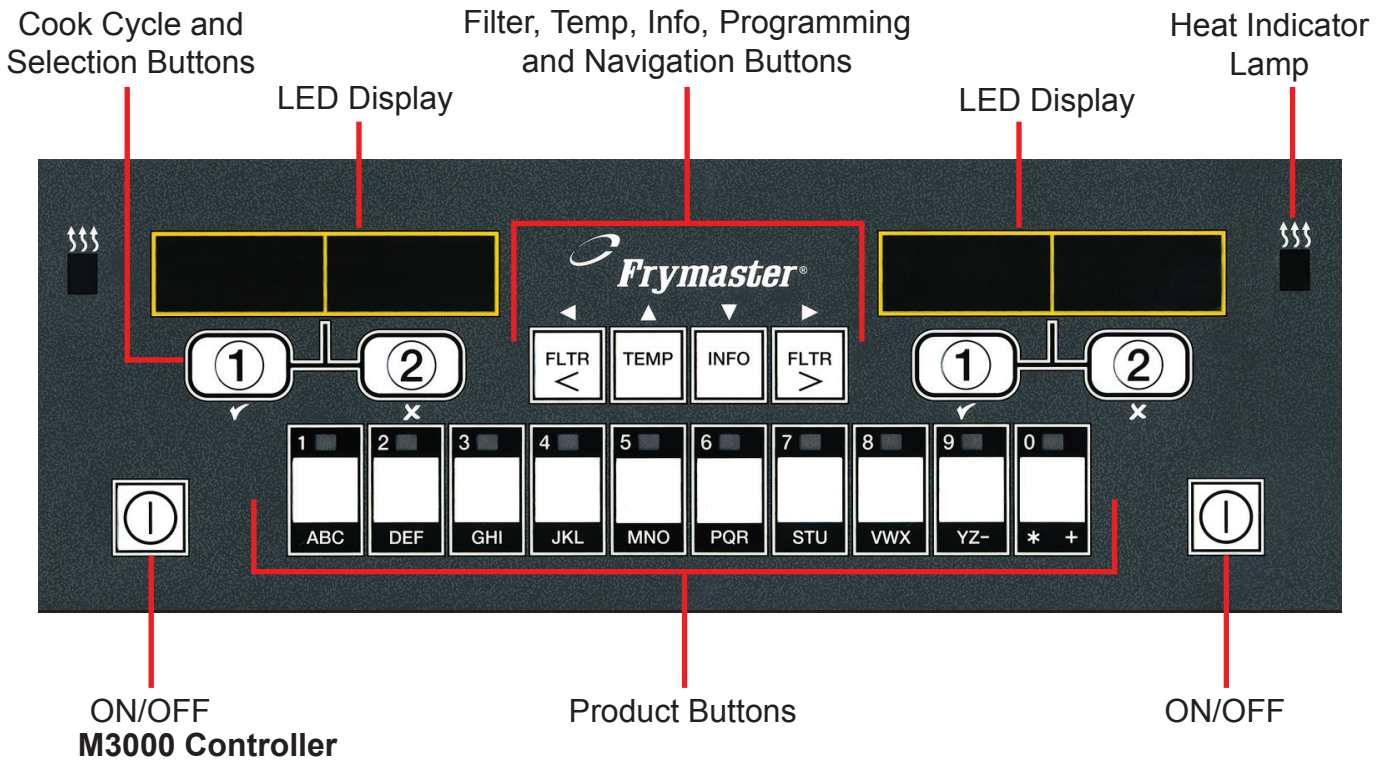

Overview

The M3000 controller retains the one-button ease of the M2000 and M100B, combining it with the utility of 40-product menu capability. It will operate with electric and gas fryers, both full- and split-vat.

On dedicated vats, press any of the cook cycle buttons to begin cooking. On non-dedicated (multi-product) vats, press a product button, and then a cook cycle button under the display showing the desired product name.

For example, a typical M3000 controller on a 3-vat fry station will display **FR FRIES**. Pressing one of the cook cycle buttons will begin a cook cycle for French fries.

The chicken/fillet station will usually display dashed lines [----]. Pressing the product button assigned to McChicken, for example, will cause **MCCHICK** to be displayed. Then, press a cook cycle button beneath the word **MCCHICK** to start a cook cycle for McChicken.



Programming
New Products in
the M3000

Video Content
Click to Play

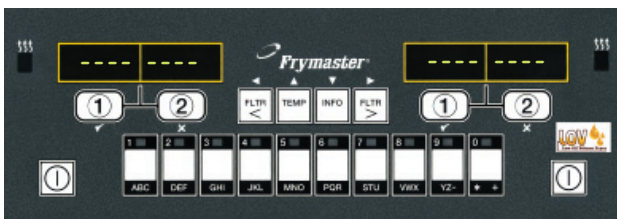

Product Buttons

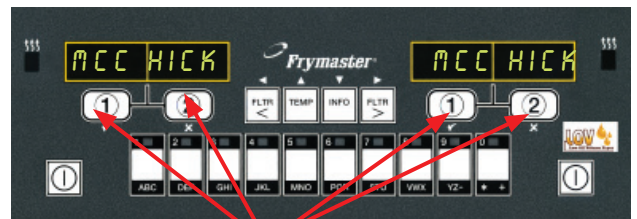

Cook Cycle Buttons

Automatic Filtering Fryers

Navigation

The M3000 uses ◀ ▶ and ▲ ▼ buttons to navigate the menus and submenus.

When programming, the left screen shows the menu or submenu item. The right screen is for data entry. Data is entered with alpha-numeric characters, scrolling through lists or by toggling between choices (see previous page).

During programming, if a button is not pushed within one minute, the controller returns to operation mode.

Cook Cycle and Selection Buttons

The ✓ and ✕ buttons are dual-function and shared with the number 1 and 2 buttons. They are located directly below the LED displays (see previous page). Use these buttons to select or cancel functions. The ✕ button is used to back out of and quit submenus.

Filter, Temperature, and Info Buttons

The < **FLTR** and **FLTR** > buttons (see diagram) are used to filter the left and right vats of a split vat fryer on demand, while the right **FLTR** > button is used to filter a full vat on demand. If pressed once, the **FLTR** buttons will display the number of cook cycles remaining until a filtration prompt. When a **FLTR** button is pressed twice, the date and time of the last filter will be displayed.

Temp Button

The **TEMP** button, if pressed once while the fryer is on, displays current vat temperature on both sides. If the **TEMP** button is pressed twice while the fryer is on, it shows the setpoint temperatures of the vats. If the fryer is off, the display shows the current versions of software.

Info Button

The **INFO** button, if pressed once when the fryer is on, shows the recovery time for each vat from the last test. Recovery displays the time required for the fryer to raise the temperature of the oil 50°F between 250°F and 300°F. Maximum recovery time should not exceed 1:40 for electric or 2:25 for gas.

If recovery time exceeds these times, the controller will display **RECOVERY FAULT**. The error can be cleared and alarm silenced by pressing the ✓ button.

If the **INFO** button is pressed and held for three seconds, it shows information such as usage, filter statistics and last cook cycles.

Automatic Filtering Fryers

This chart maps the menu options available in the M3000.

Filter Menu

- [Press and hold ◀ FLTR or FLTR ▶]
- Auto Filter
- Maint Filter
- Dispose
- Drain to Pan
- Fill Vat from Drain Pan
- Fill Vat from Bulk (Bulk Only)
- Pan to Waste (Bulk Only)

Programming

Level 1 Program

- [Press and hold TEMP and INFO buttons, 2 beeps, displays Level 1, enter 1234]
- Product Selection
 - Name
 - Cook Time
 - Temp
 - Cook ID
 - Duty Time 1
 - Duty Time 2
 - Qual Tmr
 - AIF Disable
 - Assign Btn
- AIF Clock
 - Disabled
 - Enabled
- Deep Clean Mode
- High-Limit Test
- Fryer Setup Expand to list all set-up items.

Level 2 Program (Manager Level)

- [Press and hold TEMP and INFO buttons, 3 beeps, displays Level 2, enter 1234]
- Prod Comp Sensitivity for product
- E-Log Log of last 10 error codes
- Password Setup Change passwords
 - Setup [enter 1234]
 - Usage [enter 4321]
 - Level 1 [enter 1234]
 - Level 2 [enter 1234]
- Alert Tone Volume and Tone
 - Volume 1-9
 - Tone 1-3
- Filter After Sets number of cooks before filter prompt
- Filter Time Sets amount of time between filter cycles

Tech Mode

- [Press and hold ◀ and ▶ for 10 seconds, 3 beeps, displays **TECH MODE**, enter **1650**]
- Clear Passwords
- Clear Signatures
- Filter Pad Time 25 hours or 12 hours.

Info Mode

- [Press and hold INFO for 3 seconds, displays Info Mode]
- Full/Split Vat Configuration
 - Filter Stats
 - Review Usage
 - Last Load

Automatic Filtering Fryers

M3000 Useful Codes

To enter any of the following codes: Press and hold ◀ and ▶ simultaneously for **TEN** seconds; three chirps sound. The controller displays **TECH MODE**. Enter the codes below to perform the function.

- **1658 – Change from F° to C°.** The controller displays **OFF**. Turn the controller on and check temperature to see the temperature scale. If the desired scale is not displayed, repeat.
- **3322 – Reset Factory Menu.** The controller displays **COMPLETE**, and then **OFF**. (**NOTE:** This will delete any hand-entered menu items.)
- **1650 – Enter Tech Mode.** Use to reset passwords and change filter pad time.
- **1212 – Switch Between Domestic and International Menu.** The controller displays **COMPLETE**, and then **OFF**. (**NOTE:** This will delete any hand-entered menu items.)
- **0469 – Reset FILTER STAT DATA.**

The following codes require the removal and reinsertion of the J3 locator plug on the rear of the controller before entering the code.

- **1000 – Reset CALL TECH Message.** Disconnect board locator plug (J10). Reinsert plug. . Controller display switches to **OFF**. Remove and then restore power to the controller using the 20-pin plug.
- **9988 – Reset BADCRC Message.** Disconnect board locator plug (J10). Reinsert plug. Controller display switches to **OFF**. Remove and then restore power to the controller using the 20-pin plug. The controller requires replacement.

The following codes are entered when prompted to do so or from an energy misconfigured exception error.

- **1111 – Reset SERVICE REQUIRED Message.** Enter this when the issue is fixed and you are prompted to enter.
- **1234 – Enter SETUP MODE from energy misconfigured exception error.** (This usually can be done without pressing the filter buttons if an error is displayed.)

Passwords

To enter level one, level two passwords – Press and hold the **TEMP** and **INFO** buttons simultaneously until **LEVEL 1** or **LEVEL 2** is displayed. Release the buttons and **ENTER CODE** appears.

- **1234 – Fryer Setup, Level One, and Level Two.**
- **4321 – Usage Password.**



LOV™ Quick Start:

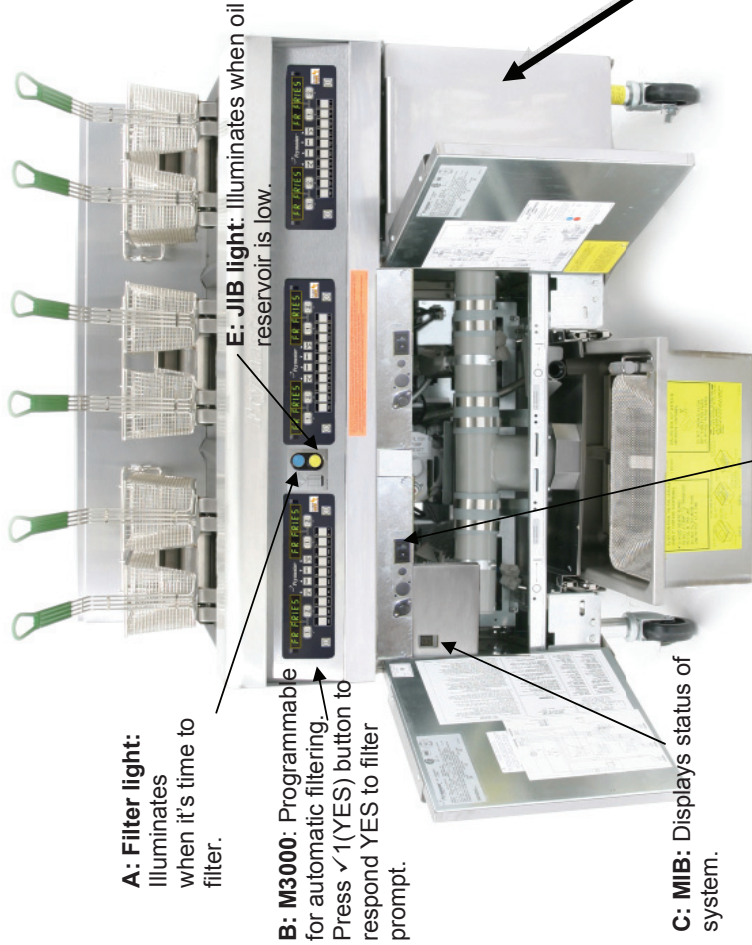

A: Filter light: Illuminates when it's time to filter.

B: M3000: Programmable for automatic filtering. Press √1(YES) button to respond YES to filter prompt.

C: MIB: Displays status of system.

E: JIB light: Illuminates when oil reservoir is low.

D: Power switch: One in cabinet under each computer (domestic electric only).



NOTE: The Frymaster LOV™ fryer requires a start-up, demonstration and training before normal restaurant operations can begin.

1. Turn on power switches (**D**).
2. Fill vats to lower fill line.
3. Turn computers on using the  button.
4. Computer displays "CHANGE FILTER PAD?" YES/NO"
5. Press √1 (YES) and computer displays "REMOVE PAN"
6. Remove pan and computer displays "CHANGE FILTER PAD"
7. Assemble filter pan, ensuring pan is out 30 seconds. Re-install filter pan.
8. Position JIB (Jug in a Box) in the right cabinet, placing pick-up tube in open jug (**G**).
9. Press and hold the JIB reset switch until light goes out. (**F**).
10. Ensure **A** is showing on the display of the MIB. A **P** indicates the filter pan is not properly placed. Reseat the filter pan if necessary.
11. While cooking, respond YES to the Filter Now Prompt in display (**B**) and illuminated blue light (**A**) by pressing the √1 (YES) button.
12. Respond to the JIB light (**E**) by replacing the JIB (**G**) and resetting (**F**) or refilling the JIB with RTI system.



F: JIB reset button: Press and hold after replacing the JIB until yellow light goes out..

G: JIB: Jug in a Box, holds oil for automatic top-off system. It's not used to fill the vats, just to maintain the oil level. Use only fresh oil in top off system.

Automatic Filtering Fryers

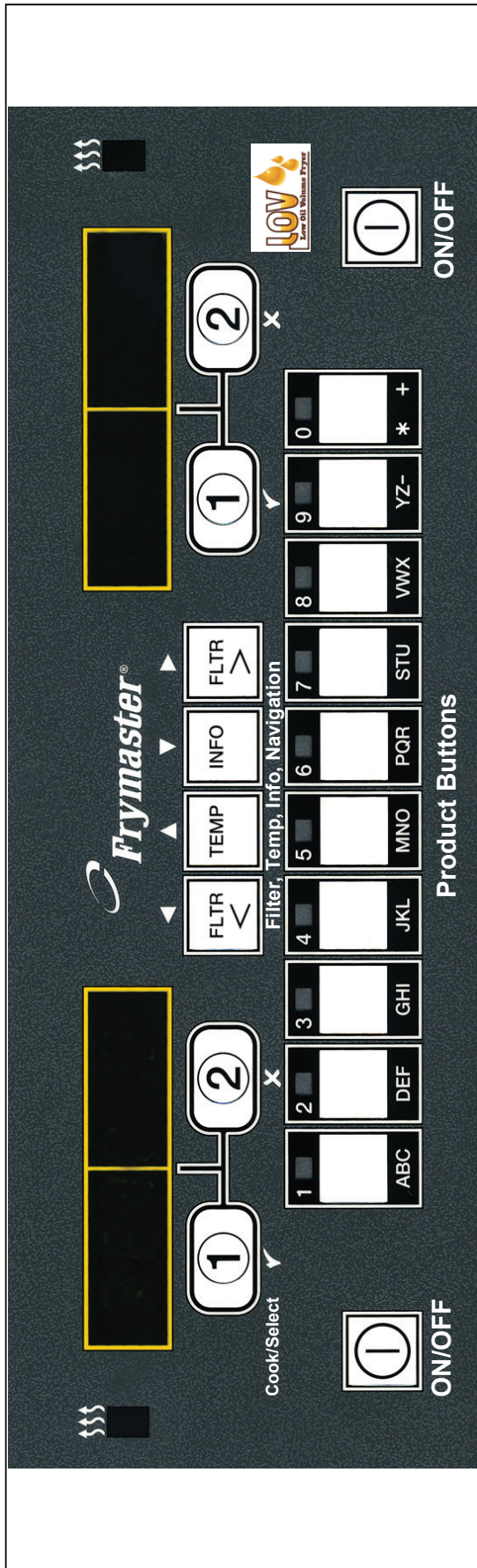

M3000 Button Guide

- ON/OFF:** Full vat: either side turns on computer. Split vat: button turns on associated side.
- Product Button:** Access menu items in multi-product mode; enter items when programming.
- Cook Cycle Buttons:** ✓1 Start cook cycles, respond yes to prompts.
✖2 Start cook cycles, respond no to prompts.
- Filter Buttons:** Press and release displays cook cycles until next automatic filter cycle. Press and hold accesses filter menu.
- Temp Button:** Press once for current temperature, twice for setpoint. Press with computer off to display software version.
- Info Button:** Press and release displays recovery time; press and hold to accesses filter statistics.
- Left/Right Cursor Buttons:** Move through menu items and advance or reverse the cursor.
- Up/Down Buttons:** Advance or reverse in programming.

Navigation Quick Reference

- Filter Menu**
Press and hold either filter button. Computer displays Filter Menu, changing to Auto Filter. Scroll to other choices with < > buttons.
Make selection with ✓1 button.
Exit, at any time, with ✖2 button.
- Programming Levels**
Level 1: Used to modify or add new items, deep clean and enable or disable automatic filtration clock.
Press and hold Temp and Info buttons.
Code appears on display.
Enter 1234 with buttons.
Computer displays Level 1 changing to Product Selection.
Scroll with < > buttons to desired item.
Make selection with ✓1 button.
Exit, at any time, with ✖2 button.
Level 2: Used to modify product compensation, set passwords, adjust tone levels, and filter frequency, see error codes.
Press and hold Temp and Info buttons for 10 sec-

- onds.
Code appears on display.
Enter 1234.
Computer displays Level 2 changing to Prod Comp. Scroll with < > buttons to desired item.
Make selection with ✓1 button.
Exit, at any time, with ✖2 button.
- Info Mode:** Used to access filter stats, review usage, last load.
Press and hold Info button for three seconds.
Computer displays Info Mode, changing to Filter Stats.
Scroll with < > buttons to desired item.
Make selection with ✓1 button.
Exit, at any time, with ✖2 button.
- Troubleshooting**
Fryer not topping off? Check JIB light, replace/refill.
Computer displays Insert Pan?: Reset filter pan.
Computer displays Is Vat Full? Yes/No: Follow displayed steps to return oil.
Computer displays Change Filter Pad?: Change filter pad, ensuring the pan is out of the fryer for at least 30 seconds.



LOV Quick Reference

Responding to Filtration Questions on the M3000 Computer Display

Is Vat Full?

1. Computer displays **IS VAT FULL?** **YES/NO** *.
2. Press ***2** (NO).
3. Computer displays **FILLING**, as the oil is being pumped back to the frypot.
4. After pumping cycle quits, computer displays **IS VAT FULL?** **YES/NO**.
5. If pot is filled press **✓1** (YES) and go to Step 9.
6. If pot is not filled, press ***2** (NO). The pump will run again for 30 seconds and display **IS VAT FULL?** **YES/NO**. (Three unsuccessful

attempts to fill the vat will lead to a **CHANGE FILTER PAD?** **YES/NO** display.)

7. Computer displays **CHANGE FILTER PAD?** **YES/NO**. Press **✓1** (YES).
8. Clean the filter pan and replace the filter pad.
9. Once the pan is pulled from the cabinet for a minimum of thirty seconds the computer display returns to the last state or OFF.
10. Re-install the filter pan.

***NOTE:** After six unsuccessful attempts to fill the vat, the fryer displays **SERVICE REQUIRED**. Pressing NO allows cooking, but the fryer will re-prompt every 15 min-

utes. Call for service.

Clogged Drain

1. Computer displays **CLEAR DRAIN** changing to **IS DRAIN CLEAR?** alternating with **YES**.
2. Clear debris from the drain using the fryer's friend and press the **✓1 YES** button once the drain is cleared to continue.
3. The computer displays **DRAINING** and normal auto filtration operation resumes.

Responding to Fryer Filter Prompts

Yes to Filter Prompt

1. Computer displays **FILTER NOW?** **YES NO** and the blue LED flashes.
2. Press **✓1** (YES).
3. Computer displays **SKIM VAT**.
4. Use skimmer to remove debris from frypot.
5. Computer displays **CONFIRM?** **YES NO**.
6. Press **✓1** (YES).
7. Computer displays **DRAINING**, **WASHING**. **FILLING** during filtration.
8. Computer displays **LOW TEMP** until back to operating temperature.
9. Computer displays product name or dashed lines.

No to Filter Prompt

1. Computer displays **FILTER NOW?** **YES NO** and the blue LED flashes.
2. Press ***2** (NO).
3. Fryer resumes normal operation.

Daily Maintenance Filtration

1. Press and hold Filter button for three seconds (right side for full vat; desired side for split vat).
2. Computer chirps, displays **FILTER MENU** and **AUTO FILTER**.
3. Use **▼** button to scroll to **MAINT FILTER**.
4. Press **✓1**.
5. Computer displays **MAINT FILTER?** and **YES NO**.
6. Press **✓1** (YES).
7. Computer displays **FIL-TERING**.
8. Oil drains from frypot
9. Computer displays **SCRUB VAT COMPLETE?** and **YES**.
10. Scrub vat and Press **✓1** (YES).
11. Computer displays **IS OIL SENSOR CLEAN?** and **YES** (gas only).
12. Clean oil sensor (gas only) with a no scratch pad and press **✓1** (YES) (see photo).
13. Computer displays **WASH VAT?** and **YES**.
14. Press **✓1** (YES).
15. Oil flows across frypot and computer displays **WASHING**.
16. Computer displays **WASH AGAIN?**

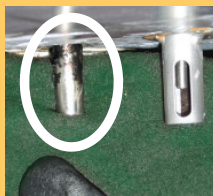

17. Press ***2** for **NO**; **✓1** for **YES**.
18. After **NO** response, computer displays **RINSING**.
19. Oil washes across frypot.
20. Computer Displays **RINSE AGAIN?** and **YES NO**.
21. Press ***2** for **NO**; **✓1** for **YES**.
22. After **NO** response, computer displays **POLISH?** and **YES NO**.
23. Press **✓1**
24. Oil flows through frypot.
25. Computer displays **POLISH-ING** and a five-minute countdown timer.

26. After five minutes, or a pressing of the ***2** button to stop the polishing, the computer displays **FILL VAT?** and **YES**.
27. Press **✓1** (YES).
28. Frypot fills and displays **FILLING**.
29. Computer displays **IS VAT FULL?** and **YES NO**.
30. Press **✓1** for yes; ***2** for no.
31. With yes selection, computer displays **OFF**.
32. With a no selection, pump runs and steps repeat, starting at step 29.

Responding to Low Oil Warning Light

JIB System (Jug In Box)

1. Orange LED on fryer lights.
2. Open cabinet door to access JIB.
3. Remove oil line from JIB
4. Remove JIB.
5. Open new oil jug and remove liner under cap.
6. Position pick-up tube in new box with attached cap in place.
7. Position the new jug in the fryer cabinet.
8. Press and hold orange reset button until orange LED goes out.

Bulk Oil System

1. Orange LED on fryer lights.
2. Open JIB door.
3. Press and hold orange reset button until the jug is full then release. **DO NOT OVERFILL THE JUG**.
4. Orange light goes out.



Daily Filter Pan Cleaning and Preparation

The filter pad in a LOV™ fryer must be replaced at least once daily. In high-volume stores it should be replaced more often.



1

Replace O-rings every 90 days.

The filter pan must be cleaned daily and the filter pad replaced. Follow these instructions to prepare the filter pan:
Remove and disassemble the pan. Discard old filter

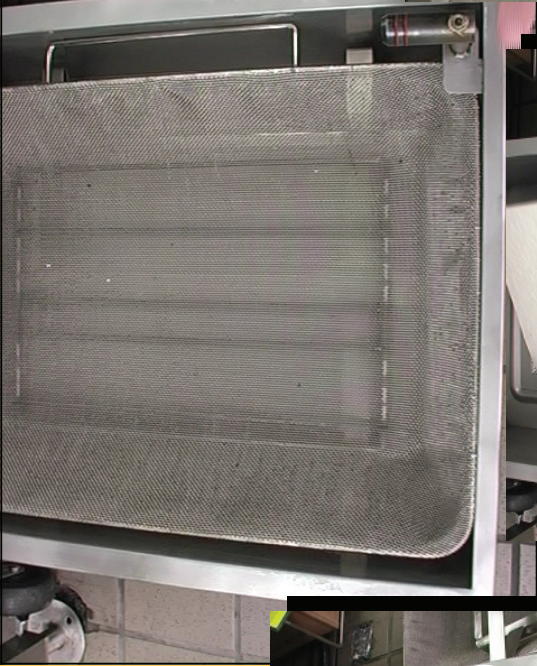

2

pad. Clean thoroughly. Leave no water in the pan. Reassemble the pan in this order:

1. Position the inner screen.
2. Place the filter pad, textured side up, in the pan.

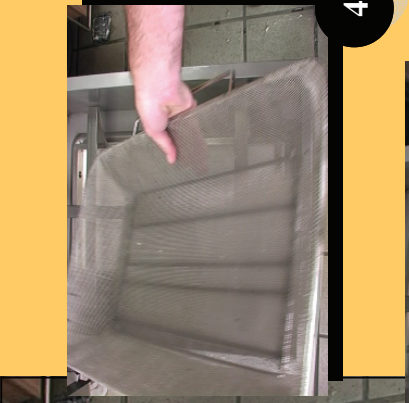

4



3

3. Position the hold-down ring on the filter pad.
4. Position the crumb tray.
5. Firmly seat the filter pan in the cabinet. Ensure the MIB display is on A.

Automatic Filtering Fryers

FilterQuick 3000 Controller Menu Tree

Main Menu and Tech Modes

[With computer OFF, press and hold ✓(check) button 10 seconds, displays Main Menu - Product Setup]

- Product Setup
 - [Enter 1650]
 - Select Product
 - Long Name
 - Short Name
 - Cooking Mode
 - 1 Time
 - 1 Tempr
 - 1 Sensitivity
 - 1 Alarm Time (Shake)
 - 1 Alarm Name (Shake)
 - 1 Alarm Mode (Shake)
 - 1 Alarm Tone (Shake)
 - 2 Alarm Time (Shake) Time entered here, produces a 3rd alarm time.
 - Filter Prompt
 - Instant On — Brings Heat On
 - Hold Time
 - Load Standard (Load Default Product Menu)

NOTE: Three alarm times are programmable. The steps for programming the 2nd alarm are just like the first. A third alarm prompt follows completion of the 2nd.

Vat Setup

- [Enter 1656]
- System
 - Language
 - 2nd Language
 - Locale (CE or Non-CE)
 - Energy (Gas or Elec)
 - Type (Vat)
 - System Volume (Sound Level)
 - Tempr Format (F or C)
 - Exit Melt Tempr
 - Cool Mode Tempr
 - Cool Mode Default
 - Fresh Oil
 - Waste
 - Recovery Alarm — Manual or Auto
 - Basket Lift
 - Hold Time

NOTE: Ensure Basket Lift is set to Disabled in Setup when attempting to change lane count.

- Time/Date
- DST(Daylight Savings Time) Setup

- Filter
 - Cooks til Filter
 - Filter Lockout
 - EOD Filter Timer
 - EOD Filter Time
 - Flushing Timer
 - Clean (Hot or Cold)
 - Clean Timer (Hot or Cold)
 - Polish Lockout
 - 1 Polish Timer
 - 1 Polish Prompt Time
 - 1 Polish Delay Timer
 - 1 Polish Duration
 - Enable Filters Percent
 - 1 Polish Start Tempr
 - Clean and Filter Timer
 - Clean and Filter Prompt Time
 - Clean and Filter Delay Timer
 - Clean and Filter Start Tempr
 - Change Filter Pad Interval H
 - OQS
 - Clean and Filter with OQS
 - OQS Type
 - Display Type – Text / Number
 - Discard Now
 - Discard Soon
 - Dispose Delay Timer

- E-Log List of last 10 error codes
- Change Password

Tech Mode

- [Enter 3000]
- Clear E-Log
- Clear Passwords
- Lane Count
- Hold Mode
- Hi-Limit Test

NOTE: If the lane count doesn't change, set the basket lift to disabled in Vat Setup.

NOTE: A programming option is available in TECH MODE called "Hold Mode" that will either allow the product's hold time to count down in the background or count down in the foreground.

Automatic Filtering Fryers

FilterQuick Controller Useful Codes

To enter any of the following codes: Press and hold the ✓ button until *MAIN MENU* changing to *PRODUCT SETUP* is displayed. Press ► to scroll to Tech Mode and press *TECH MODE*. *ENTER CODE* is displayed. Press the ✓ button. Enter a code number below to perform a function.

- **1658 – Change from F° to C°.** The controller displays off. Turn the controller on and check temperature to see the temperature scale. If the desired scale is not displayed, repeat.
- **3322 – Reset Factory Menu.** The controller display flashes and quickly counts from 1-40 and switches to off. (NOTE: This will delete any hand-entered menu items).
- **3000 – Clear E-Log, Clear Passwords, Change Lane Count, Change Hold Mode and Perform High Limit Test.**
- **0042 – Reset Recovery Fault Call Service.**

The following codes require the removal and reinsertion of the J3 locator plug on the rear of the controller before entering the code.

- **1000 — Reset CALL TECH Message** - Disconnect board locator plug (J3). Reinsert plug. Controller display switches to off. Remove and then restore power to the controller using the 20-pin plug. If this error is displayed, replace the controller.
- **9988 — Reset BADCRC Message** - Disconnect board locator plug (J3). Reinsert plug. Controller display switches to off. Remove and then restore power to the controller using the 20-pin plug. Replace the controller.

Passwords

- **Product Setup Mode:** Press and hold the ✓ button until *MAIN MENU* changing to *PRODUCT SETUP* is displayed. Press the ✓ button. *ENTER CODE* is displayed. **Enter 1650.**
- **Vat Setup Mode:** Press and hold the ✓ button. *MAIN MENU* changing to *PRODUCT SETUP* is displayed. Press ► to scroll to *VAT SETUP* and press ✓. *ENTER CODE* is displayed. **Enter 1656.**
- **Tech Mode:** Press and hold the ✓ button until *MAIN MENU* changing to *PRODUCT SETUP* is displayed. Press ► to scroll to Tech Mode and press ✓. *TECH MODE* is displayed. Press the ✓ button. *ENTER CODE* is displayed. **Enter 3000.**

Automatic Filtering Fryers

Navigation

ON/OFF

• Press ON/OFF button. Fryer begins melt cycle to slowly heat solid shortening to programmed temperature before switching to full temperature and heating to setpoint and displays: READY.

• **Exit Melt Cycle**, when using liquid oil, by pressing and releasing the Exit Cool button or any programmed product button. Displays show Exit Melt? on left and YES NO on the right. Press button under Yes to exit.

Cooking

• **COOL** displayed: Press product button or Exit Cool; fryer heats to setpoint and displays READY.

• **READY** displayed: Press product button and drop product.

• ----- displayed: The vat temperature is out of the Ready zone.

• **DONE** displayed: Press blinking product button to cancel alarm and end a cook.

• **HOLD** displayed: Press blinking product button to cancel hold alarm.

• **Cancel a Cook**: Press and hold blinking product button to cancel cook cycle.

Change Setpoint: Press a product button with the desired temperature. Press the product button again and a cook starts. NOTE: When a product button with a setpoint different than a currently cooking product is pressed, a low tone is heard and the new cook won't start until the cook is finished.

Controller Button Navigation

• **Product**: Press to start a cook cycle. Active when adjacent LED is lit. LED flashes during a cook cycle. Press and hold to cancel a cook cycle. Press at end of cook cycle to cancel an alarm. Press and hold a product with different setpoint to change setpoint temperature.

• **Exit/ Scan**: Press once; all product buttons are lit. Select Product displayed. Press product button to view product name. Press ✓ to advance through all product parameters. Press Exit Scan again to repeat. Press Exit Scan twice to escape.

• **Left/Right Arrows**: Navigate options in left display. Press both simultaneously to start a polish cycle.

• **Up/Down Arrows**: Navigate options in right display. Press both simultaneously to change to a second language if one is selected in setup.

• **Exit Cool**: Exits cool mode, returns fryer to setpoint temperature.

• **Thermometer, Fryer ON**: Press and release for setpoint in left display and vat temperature in right display.

• **Thermometer, Fryer OFF**: Press to display temperature, time, date, system version, controller and circuit board software versions.

• **Checkmark, Fryer OFF**: Press and hold 3 seconds: Scroll filter usage; Press and hold 10 seconds: Product setup.

• **Checkmark, Fryer ON**: Enter Codes, Respond to left display prompts.

• **Filter, Press and Release**: Cooks remaining to filter cycle. Press and hold: Filter options: Filter, Clean and Filter, Dispose, Fill Vat from Bulk (Bulk option only) and Boil Out (OFF only).

FilterQuick™: Quick Reference

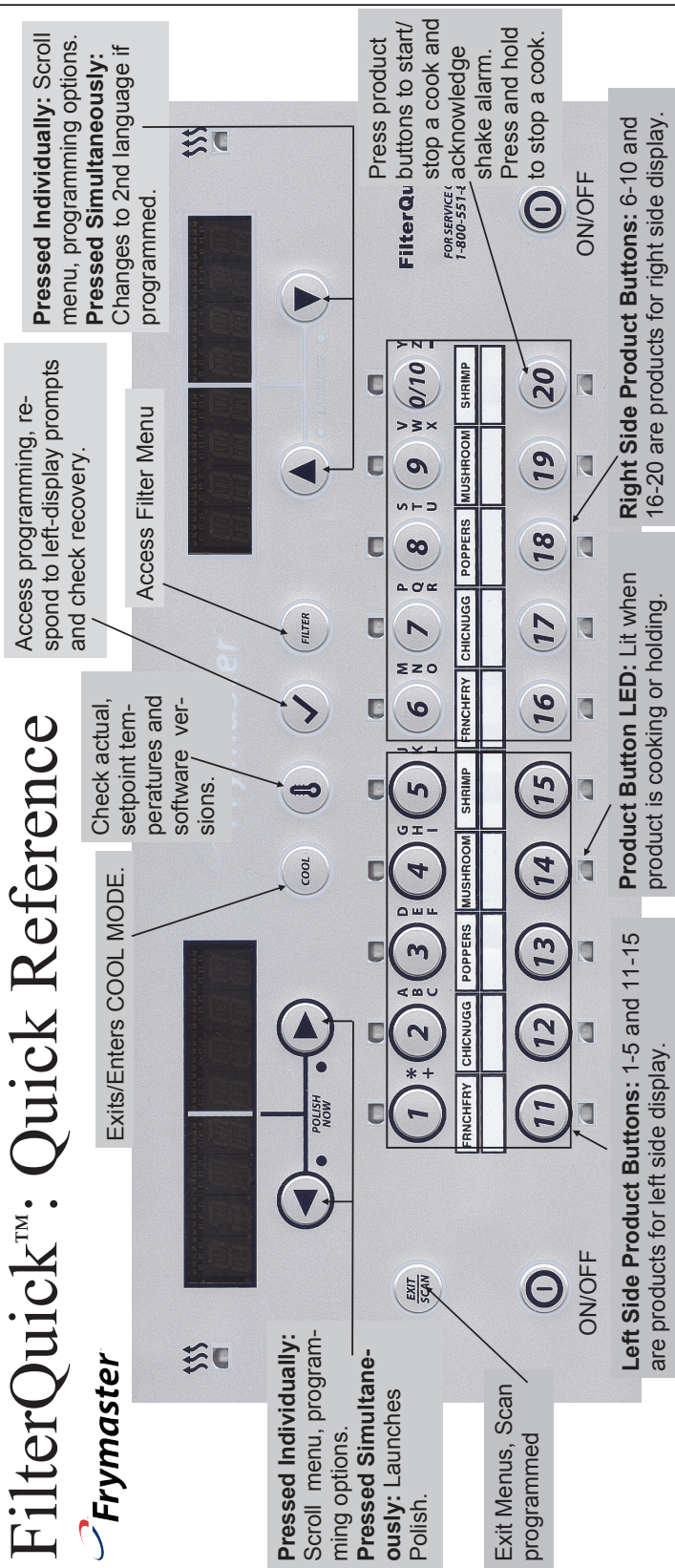

- ON/OFF**
- Press ON/OFF button. Fryer enters melt cycle before switching to full temperature and heating to setpoint.
 - Exit melt cycle by pressing and releasing the Exit Cool button or any programmed product button. Displays show Exit Melt? on left and YES NO on the right. Press ▲ to exit.
- Cooking**
- **COOL displayed:** Press product button or Exit Cool button; fryer heats to setpoint and displays READY.
 - Press product button and drop product.
 - - - - - **displayed:** The vat temperature is out of the READY zone.
 - **READY displayed:** Press product button and drop product.
 - **SHAKE displayed:** If shake is needed, alarm sounds. Press blinking product button to cancel alarm.
 - **DONE displayed:** Press product button to cancel alarm.
- Controller Button Navigation**
- **Product:** Press to start cook cycle. Press at end of cook cycle to stop alarm.
 - **Exit/Scan:** Press once, all programmed product buttons are lit; Select Product displayed. Press product button to view product name. Press right arrow to view parameters. Press Exit/Scan again to repeat. Press Exit/Scan twice to escape.
 - **Left/Right Arrows (◀▶):** Navigate options in left display. Press and hold simultaneously to launch Polish cycle.
 - **Up/Down Arrows (▼▲):** Navigate options in right display. Press and hold simultaneously to change language if programmed.
 - **Exit Cool:** Press to enter/exit Cool Mode.
- cancel alarm.**
- **HOLD displayed:** Press blinking product button to cancel hold alarm.
 - **Cancel Cook Cycle:** Press and hold product button.
- Thermometer (I): Fryer ON:** Press and release for setpoint/left; vat temp/right.
- Thermometer (I): Fryer OFF:** Press and release to display temperature, time, date, system version, FilterQuick version, circuit board versions.
- Checkmark (✓): Fryer OFF:** Press and release: Check recovery; Press and hold 3 seconds: Scroll filter usage; Press and hold 10 seconds: Main Menu-Product setup.
- Checkmark (✓): Fryer ON:** Press and release: Check recovery; Press and hold 4 seconds: Info Mode.
- Filter: Press and hold:** Filter options: FILTER, CLEAN AND FILTER, DISPOSE, DRAIN TO PAN, BOIL OUT or CLEAN, FILL VAT FROM PAN, PAN TO WASTE (Bulk only) and FILL VAT FROM BULK (Bulk only).
- Filter: Press and release:** Displays total percentage of products cooked and cooks remaining to filter cycle.

Automatic Filtering Fryers

column show the computer displays; the right column has the action necessary to continue. Exit from a programming step at any time by pressing the Scan key until the display returns to its pre-programming status. To delete a product from a button enter a time of 0:00 and press the SCAN button.

Programming

Left Display	Right Display	Action
OFF	OFF	Press ✓ until Main Menu changing to Product Setup is displayed.
PRODUCT setup	Blank	Press ✓.
Product Setup	Enter Code	Enter 1650.
Select Product	Blank	Press desired product button.
LONG Name	Product name or button number	Enter product name with letter keys. Press ▶.
Short Name	Product name or button number	Enter abbreviated product name with letter keys. Press ▶.
COOKING MODE	SINGLE SET-POINT	Press ▶. If multiple setpoint cooking is desired press ▼ MULTIPLE SETPOINT .
1 Time	0:00 or previously entered time	Enter time with numbered keys. Press ▶. (Enter 0:00 here and press Exit/Scan to unassign a button.)
1 TempR	Temp	Enter new temperature. Press ▶.
1 SENSITIVITY	Number	Set to desired position with ▼▲keys. Press ▶.
1 Alarm TIME	0:00 or previously entered time	Enter time in cook cycle for audible alarm for shaking. Press ▶.
1 alarm name	Shake	Set to desired position with ▼▲ keys. Press ▶.
1 Alarm Mode	Auto or manual	Set to desired position with ▼▲keys. Press ▶.
1 Alarm tone	Short	Set to desired position with ▼▲keys. Press ▶.
2 Alarm Time	:00	This is a second alarm and is entered like the first.
Filter Prompt	0	Enter the number of cook cycles for the product before a filter cycle is prompted.
Instant On	0 or previously set number	This is the time, in seconds, the fryer heats at 100%, after the product button is pressed before the controller adjusts the temperature. Enter value and press ▶. (Default is 5. 0=OFF). NOTE: Instant on time may need to be adjusted for light cooking loads.
HOLD TIME	0	Enter time in minutes to hold product before discarding. Press ▶.

Press Cook button to exit on the / button for

Left Display	Right Display	Action
COOL or READY	COOL or READY	Press and hold Filter button for 10 seconds
Filter	Blank	Press ▶ to scroll to choices: Filter, Clean and Filter, Dispose, Drain to Pan, Boil Out or Clean, Fill Vat from Pan, Pan to Waste (Bulk only), Fill Vat from Bulk (Bulk only) and Exit. With the desired choice displayed press ✓. (NOTE: Some choices are only available in the "ON" mode and some are only available when in the "OFF" mode.)

Responding to Fryer Filter Prompts

Yes to Filter Prompt

1. Controller displays **FILTER NOWP YES NO**.
2. Press ▲ (YES).
3. Controller displays **SKIM VAT**.
4. Use skimmer to remove debris from frypot.
5. Controller displays **START FILTRATION** and blue drain LED blinks.
6. Push the button with the blinking LED.
7. Controller displays **DRAINING** and **FLUSHING** during filtration.
8. Controller displays **FILLING** while the vat is filling.
9. Controller displays **LOW TEMP** alternating with the temperature or - - - - until back to operating temperature.
10. Controller displays **READY**.

No to Filter Prompt

1. Controller displays **FILTER NOWP YES NO**.
2. Press (NO).
3. Fryer resumes normal operation.

Responding to Low Oil Warning

JIB System (Jug In Box)

1. Controller displays **TOPOFF OIL EMPTY** in the left display and **CONFIRM** in the right display. Press ▲ (CONFIRM).
2. Open cabinet door to access JIB.
3. Remove oil line from JIB
4. Remove JIB.
5. Open new oil jug and remove liner under cap.
6. Position pick-up tube in new box with attached cap in place.
7. Position the new jug in the fryer cabinet.
8. Press and hold orange reset button for three (3) seconds to reset system.

FilterQuick™ Quick Start:

A: FQ3000: Programmable for automatic filtering. Press (YES) button to respond YES to filter prompt.

B: Power switch: One in cabinet (electric only) under each fryer.

C: MIB: Displays status of system.

H: Blue Filter Button

F: Pick-up tube

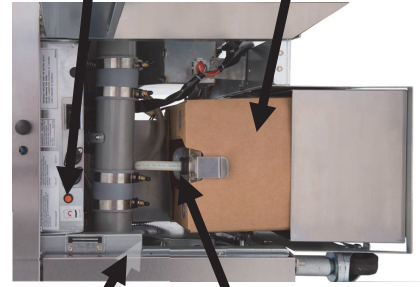
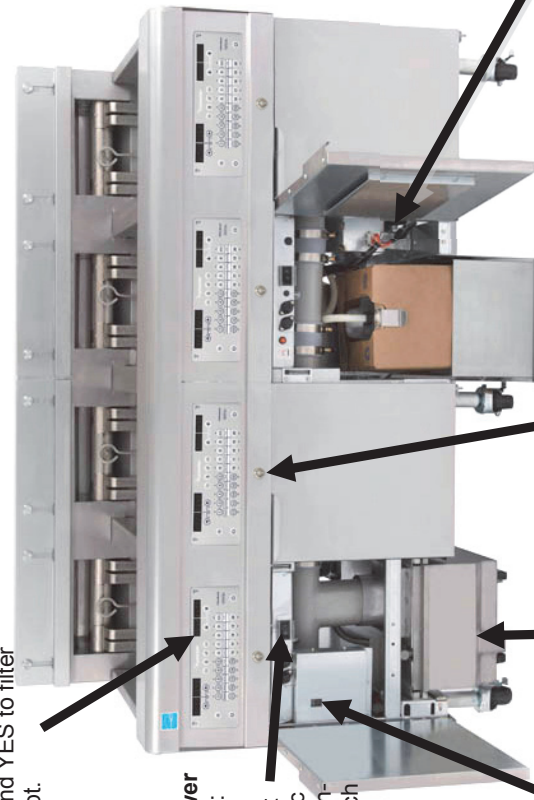

D: Top off reset button: Press and hold orange button after replacing the oil until top off empty notice goes out.

E: Oil Container: Holds oil for automatic/manual top-off system. It's not used to fill the vats, just to maintain the oil level. Use only fresh oil in top off system.

Automatic Filtering Fryers

1. Fill vats with oil to lower fill line.
2. Turn on power switches if applicable (D).
3. Turn controllers on by pressing the power button. 
4. Controller (A) displays "CHANGE FILTER PAD? YES/NO"
5. Press (YES) and controller displays "REMOVE PAN"
6. Remove filter pan (G) and computer displays "CHANGE FILTER PAD"
7. Assemble filter pan, ensuring pan is out 30 seconds. Re-install filter pan.
8. Position oil container [JIB (Jug in a Box)] in the right cabinet, placing pick-up tube (F) in open oil container (E).
9. Press and hold the top off reset switch (D) until JIB is full or Top Off Empty display goes out on controller (A).
10. Ensure an "A" is showing on the display of the MIB. A "P" indicates the filter pan is not properly placed. Reseat the filter pan if necessary.
11. While cooking, respond YES to the Filter Now Prompt in display (A) by pressing the (YES) button and pressing the BLUE filter button when blinking (H).
12. Respond to the empty oil container Top Off Empty notification by replacing the oil container (E) and resetting the top off reset switch (D) or refilling the oil container with bulk oil system.



FRY_QR_8197458 06/2017

FRYMASTER®

NOTE: The Frymaster FilterQuick™ fryer requires a start-up, demonstration and training before normal restaurant operations can begin.

Daily Filter Pan Cleaning and Preparation

The filter paper in a FilterQuick™ fryer must be replaced at least once daily. In high-volume stores it should be replaced more often. Use Frymaster PN 8030445 16.5" x 25.5" filter paper.

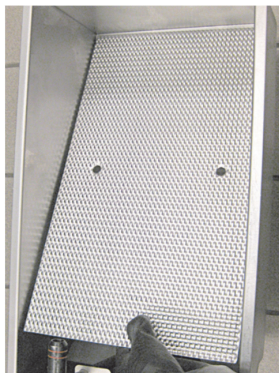

1

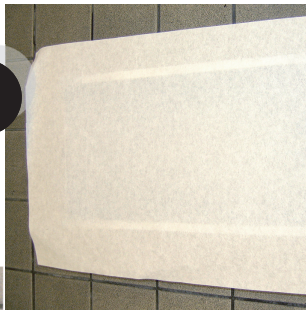

2

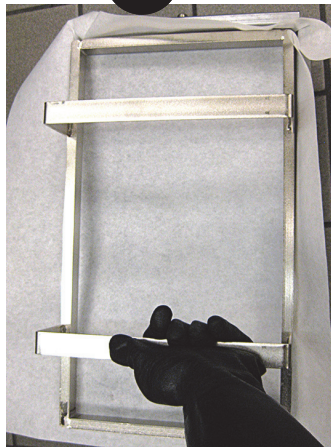

3



4



5

Replace O-rings every 90 days.



6

The filter pan must be cleaned daily and the filter paper replaced. Follow these instructions to prepare the filter pan:

Remove and disassemble the pan. Discard old filter paper. Clean thoroughly. **Do NOT leave any water in the pan.**

Reassemble the pan in this order:

1. Position the inner screen.
2. Place the filter paper on the pan.
3. Position the hold-down ring on the filter paper and lower

4. Ensure the paper is folded up around the hold down ring.
5. Position the crumb tray.
6. Firmly seat the filter pan in the fryer. Ensure the "A" is visible on the display above the filter pan.



Automatic Filtering Fryers

LOV/FQ Error Codes

CODE	ERROR MESSAGE	EXPLANATION
E01	M3000 ONLY REMOVE DISCARD (Right)	A product cook is started on the right side of a split vat or in a full vat that has a different setpoint other than the current vat temperature.
E02	M3000 ONLY REMOVE DISCARD (Left)	A product cook is started on the right side of a split vat or in a full vat that has a different setpoint other than the current vat temperature.
E03	ERROR TEMP PROBE FAILURE	TEMP Probe reading out of range.
E04	HI 2 BAD	High limit reading is out of range.
E05	HOT HI 1	High limit temperature is more than 410°F (210°C), or in CE countries, 395°F (202°C).
E06	HEATING FAILURE	A component has failed in the high limit circuit such as controller, interface board, contactor or open-high limit.
E07	ERROR MIB SOFTWARE	Internal MIB software error.
E08	ERROR ATO BOARD	MIB detects ATO board connection lost; ATO board failure.
E09	ERROR PUMP NOT FILLING	Oil not returning to vat quickly. Possible problems: dirty pad, bad or missing O-rings, tripped or defective filter pump, actuators or linkage.
E10	ERROR DRAIN VALVE NOT OPEN	Drain valve failed to open; valve's position is unknown.
E11	ERROR DRAIN VALVE NOT CLOSED	Drain valve failed to close; valve's position is unknown.
E12	ERROR RETURN VALVE NOT OPEN	Return valve failed to open; valve's position is unknown.
E13	ERROR RETURN VALVE NOT CLOSED	Return valve failed to close; valve's position is unknown.
E14	ERROR AIF BOARD	MIB detects AIF missing; AIF board failure.
E15	ERROR MIB BOARD	Cooking controller detects MIB connections lost; check software version on each controller. If versions are missing, check CAN connections between each controller; MIB board failure.
E16	ERROR AIF PROBE	AIF RTD reading out of range.
E17	ERROR ATO PROBE	ATO RTD reading out of range.
E18	Not Used	
E19	CAN TX FULL©	Connection between controllers lost.
E20	INVALID CODE LOCATION	SD card removed during update.
E21	FILTER PAD/PAPER PROCEDURE ERROR (Change Filter Pad or Paper)	25 hour timer has expired or dirty filter logic has activated.
E22	OIL IN PAN ERROR	The MIB has detected oil may be in the pan.
E23	CLOGGED DRAIN (Gas)	Vat did not empty during filtration.
E24	OIL RETURN (level) SENSOR FAILED (Gas)	Oil return sensor may have failed.
E25	RECOVERY FAULT	Recovery time exceeded maximum time limit.
E26	M3000 ONLY RECOVERY FAULT CALL SERVICE	Recovery time exceeded maximum time limit for two or more cycles.
E27	LOW TEMP ALARM	Oil temperature has dropped lower than 15°F (8°C) in idle mode or 45°F (25°C) in cook mode.
E28	FilterQuick3000 ONLY HIGH TEMP ALARM	Oil temperature has risen 40°F (22.2°C) higher than setpoint. If temperature continues to rise, the high limit will shut the power off at 425°F (218°C) Non-CE or 395°F (202°C) CE.

Automatic Filtering Fryers

FilterQuick 3000 OQS Error Codes

Code	Message	Description
E70	OQS Temp High	Oil temperature is too high. Filter between 300°F and 375°F.
E71	OQS Temp Low	Oil temperature is too low. Filter between 300°F and 375°F.
E72	TPM Range Low	The TPM is too low. This may be seen with new oil. The incorrect oil type may be selected in the setup menu. The sensor may not be calibrated for the oil type. See oil type chart in instruction document 8197316. If issue continues contact an FAS.
E73	TPM Range High	The TPM reading is too high. Dispose the oil.
E74	OQS Error	The OQS has an internal error. If issue continues contact an FAS.
E75	OQS Air Error	The sensor is detecting air in the oil. Check the O-rings and check/tighten prescreen filter to ensure no air is entering the OQS sensor. If issue continues contact an FAS.
E76	OQS ERROR	The OQS sensor has a communication error. Check connections to the OQS sensor. Power cycle the entire fryer battery. If issue continues contact an FAS.
E77-E80	N/A	

Automatic Filtering Fryers

M3000/FilterQuick 3000 Controller Troubleshooting

Problem	Probable Causes	Corrective Action
<p>• No display on controller.</p>	<p>A. Controller not turned on.</p> <p>B. No power to the fryer.</p> <p>C. Power switch turned off.</p> <p>D. Loose fuse holder.</p> <p>E. Controller has failed.</p> <p>F. Damaged controller wiring harness.</p> <p>G. Power supply component or interface board has failed.</p>	<p>A. Press the ON/OFF switch to turn the controller on.</p> <p>B. This fryer may have two cords: a controller power cord and a main power cord. If the controller cord is not plugged in, the controller will not activate. Verify controller power cord is plugged in and that circuit breaker is not tripped.</p> <p>C. Some fryers have a rocker power switch inside the cabinet below the controller. Ensure the switch is turned on.</p> <p>D. Ensure fuse holder is screwed in properly.</p> <p>E. Swap the controller with a controller known to be good. If controller functions, replace the controller.</p> <p>F. Swap with a harness known to be good. If controller functions, replace the harness.</p> <p>G. If any component in the power supply system (including the transformer and interface board) fails, power will not be supplied to the controller and it will not function.</p>
<p>• Controller locks up.</p>	<p>Controller error.</p>	<p>Remove and restore power to the controller.</p>
<p>• Controller displays FILTER BUSY.</p>	<p>A. Another filtration cycle is still in process.</p> <p>B. Controller error.</p> <p>C. Controller error.</p>	<p>A. Wait until the previous filtration cycle ends to start another filtration cycle.</p> <p>B. M3000 only: A controller has an error. Using the filter menu, try to perform a FILL VAT FROM DRAIN PAN on each vat (see Chapter 4 of the BIELA14 IO manual). Only controllers with errors can perform this function with a filter busy error. Controller should clear and return to normal operation once complete.</p> <p>C. If filter busy is still displayed with no activity, ensure the filter pan is empty and remove and restore ALL power to the fryer with hidden reset button.</p>

Automatic Filtering Fryers

Problem	Probable Causes	Corrective Action
<p>•Controller displays RECOVERY FAULT.</p>	Recovery time exceeded maximum time limit.	Silence the alarm by pressing the ✓ button. Check that fryer is heating properly. Maximum recovery for electric is 1:40. Maximum recovery for gas is 2:25.
<p>M3000 ONLY Display shows ENERGY MISCONFIGURED</p>	Wrong energy type selected in setup.	Press 1234 to enter setup and set energy type for electric.
<p>M3000 ONLY Display shows EXCEPTION ERROR with the description on the right.</p>	An error has occurred.	Press 1234 to enter setup and reconfigure the controller.
<p>•Controller displays SERVICE REQUIRED followed by the error.</p>	An error has occurred.	Press YES to silence alarm. The error is displayed three times. See list of issues on pages 1-53 — 1-60. Fix issue. The controller displays SYSTEM ERROR FIXED? YES/ NO. FilterQuick 3000: Press YES; follow prompts. M3000 ONLY: Controller displays ENTER CODE. Enter 1111 to clear error code. Pressing NO will allow the fryer to cook, but error will be redisplayed every 15 minutes.
<p>•Controller display is in wrong temperature scale (Fahrenheit or Celsius).</p>	Incorrect display option programmed.	See controller manual to change temperature scale.
<p>•Controller displays CHANGE FILTER PAD OR PAPER.</p>	Filter error has occurred, filter pad clogged, 24 hour filter pad change prompt has occurred, or change filter pad was ignored on a prior prompt.	Change the filter pad or paper and ensure the filter pan has been removed from the fryer for a minimum of 30 seconds. Do NOT ignore CHANGE FILTER PAD/PAPER prompts.
<p>•Controller displays INSERT PAN.</p>	<p>A. Filter pan is not fully inserted into fryer. B. Missing filter pan magnet. C. Defective filter pan switch.</p>	<p>A. Pull filter pan out and fully reinsert into fryer. B. Ensure the filter pan magnet is in place; replace if missing. C. If the filter pan magnet is fully against the switch and controller continues to display INSERT PAN, switch is possibly defective.</p>
<p>•Controller display shows HOT-HI-1.</p>	Frypot temperature is more than 410°F or, in CE countries, 395°F.	This is an indication of a malfunction in the temperature control circuitry, including a failure of the high-limit thermostat.

Automatic Filtering Fryers

Problem	Probable Causes	Corrective Action
<p>•Controller display shows HI-LIMIT.</p>	<p>Controller in high-limit test mode.</p>	<p>This is displayed only during a test of the high-limit circuit and indicates that the high-limit has opened properly.</p>
<p>•Controller display shows LOW TEMP (current temp on FilterQuick 3000) alternating with MLT-CYCL.</p>	<p>Frypot temperature is below 180°F.</p>	<p>This display is normal when the fryer is first turned on while in the melt cycle mode. To bypass the melt cycle mode. To bypass the melt cycle M3000: press and hold either #1 or #2 product button under the LED display until a chirp is heard. FilterQuick: Press Cool Button. The controller displays EXIT MELT alternating with YES and NO. Press the #1 YES button to exit melt. If the display continues, the fryer is not heating.</p>
<p>Controller displays ERROR RM SDCRD</p>	<p>Defective SD card.</p>	<p>Replace card with another card.</p>
<p>• Controller displays TEMP PROBE FAILURE.</p>	<p>A. Problem with the temperature measuring circuitry including the probe. B. Damaged controller wiring harness or connector.</p>	<p>A. This indicates a problem within the temperature measuring circuitry. Check resistance of probe, if faulty replace probe. B. Swap the controller wiring harness with one known to be good. If problem is corrected, replace the harness.</p>
<p>M3000 ONLY MAINT FILTER (Manual Filter) won't start.</p>	<p>Temperature too low.</p>	<p>Ensure fryer is at setpoint before starting MAINT FILTER.</p>
<p>M3000 ONLY Controller display shows REMOVE DISCARD.</p>	<p>In non-dedicated mode, a product is dropped that has a different setpoint than the current vat temperature.</p>	<p>Remove and discard product. Press a cook button under the display with the error to remove the error. Reset the setpoint of the vat before trying to cook product.</p>
<p>•Controller displays HEATING FAILURE.</p>	<p>Failed controller, failed interface board, open high-limit thermostat.</p>	<p>Turn off the vat with the problem. This error is displayed if the fryer loses its ability to heat oil. It is also displayed when the oil temperature is above 450°F and the high-limit thermostat has opened, halting the heating of the oil.</p>
<p>•Controller will not go into program mode or some buttons do not actuate.</p>	<p>Failed controller.</p>	<p>Replace controller</p>

Automatic Filtering Fryers

Problem	Probable Causes	Corrective Action
<p>•Controller displays HI 2 BAD.</p>	<p>Controller in high-limit test mode.</p>	<p>This is displayed during a test of the high-limit circuit to indicate if the high-limit has failed.</p>
<p>• Controller displays HELP HI-2 or HIGH LIMIT FAILURE.</p>	<p>Failed high-limit.</p>	<p>This is displayed to indicate the high-limit has failed.</p>
<p>•Controller displays only controller or MIB software but not all boards.</p>	<p>Loose or damaged harness.</p>	<p>Check that all harnesses between controllers, MIB, AIF and ATO are secure. Ensure 24VDC is present on pins 5 & 6 of J2 on MIB board and on J4 or J5 of AIF board. Check for loose or broken pins/wires. If the problem persists, swap out controller from one bank to another and cycle power on the fryer.</p>
<p>•Controller displays LOW TEMP, heating indicator cycles on and off normally but fryer does not heat.</p>	<p>A. Three phase power cord unplugged or circuit breaker is tripped. B. Failed controller. C. Damaged controller wiring harness. D. Open connection in high-limit circuit.</p>	<p>A. Ensure all cords are fully seated in the receptacles, locked into place and that circuit breakers are not tripped. B. Replace controller. C. Replace controller wiring harness. D. Check high limit circuit starting at the control box connector working to the high-limit.</p>
<p>•Controller displays IS VAT FULL? YES NO.</p>	<p>A filter error has occurred due to dirty or clogged filter pad or paper, clogged filter pump, filter pump thermal overload, improperly installed filter pan components, worn or missing O-rings, cold oil or an actuator problem.</p>	<p>Follow the steps in the flowchart on pages 1-40 — 1-41.</p>
<p>•Fryer filters after each cook cycle.</p>	<p>Filter after setting incorrect or software update issue.</p>	<p>M3000: Overwrite the filter after setting by re-entering the filter after value in level two. Ensure that the down arrow is pressed after entering the value to save the setting. FilterQuick: Overwrite the filter setting by re-entering the filter prompt value in Product Setup.</p>

Automatic Filtering Fryers

Loading and Updating Software Procedures on M3000

Updating the software takes approximately 20 minutes. To update the software, follow these steps:

1. Switch all controllers to **OFF**. Press the **TEMP** button to check current M3000/MIB/AIF/ATO software version.
2. Remove the two screws on the left side cover plate of the M3000 board.
3. With the controller folded down, insert the SD card into the slot on the left side of the M3000. The contacts on the card should face down and the notch should appear on the bottom right (see pictures below).
4. Once inserted, **UPGRADE IN PROGRESS** appears on the left display and **WAIT** on the right.
5. The display then changes to **CC UPDATING** on the left and the percentage completed appears on the right. The display counts up to 100 on the right, changing to a flashing **BOOT**. **DO NOT REMOVE THE CARD UNTIL THE DISPLAY PROMPTS TO DO SO IN STEP 8.**
6. Then, **UPGRADE IN PROGRESS** is displayed on the left display and **WAIT** on the right again, followed by **COOK HEX, MIB HEX, AIF HEX** ending with **ATO HEX** displayed on the left and the percentage complete on the right.
7. The display then changes to **REMOVED SD CARD** on the left and **100** on the right.
8. Remove the SD card using the fingernail slot on the top of the SD card.
9. Once the SD card is removed, the display changes to **CYCLE POWER**.
10. Cycle the control power using the hidden reset switch behind the right control box on electric or under left control box on gas. **HOLD THE SWITCH FOR 10 SECONDS ENSURING THE MIB BOARD HAS POWERED FULLY DOWN.**
11. A flashing **BOOT** is displayed on the remaining controllers while the program is transferred.
12. When the update is complete, the M3000 displays **OFF**. The MIB display will remain blank while software is loading, changing to show the vat numbers. Once the LEDs stop blinking, press **YES** if the **SYSTEM ERROR FIXED?** is displayed. Enter 1111. The MIB board will display **A**.
13. Cycle the control power using the hidden reset switch behind the right control box on electric and under left control box on gas again. **ENSURE THE SWITCH IS HELD FOR 10 SECONDS. WAIT ANOTHER 20 SECONDS UNTIL THE MIB BOARD HAS FULLY RESET BEFORE CONTINUING.**
14. **With the controller displaying OFF, VERIFY software update by pressing the TEMP button to check updated M3000/MIB/AIF/ATO version on each controller. IF ANY BOARDS DID NOT UPDATE, REPEAT THE PROCESS STARTING WITH STEP 3.**

Insert the SD card with contacts facing down.



Remove the SD card using the fingernail slot on the top of the card.



Automatic Filtering Fryers

Service Required Errors

A **SERVICE REQUIRED** error alternating with **YES** displays on the controller. After **YES** is pressed the alarm is silenced. The controller displays an error message from the list below three times with the location of the error. Then, the controller displays **SYSTEM ERROR FIXED? YES/NO**. If **YES** is chosen, enter code **1111**. If **NO** is chosen, the system returns to cook mode for 15 minutes then re-displays error until issue is fixed.

Pressing the MIB reset button during any filter function will generate a SERVICE REQUIRED error.

This is a list of the service required errors and cause.

ERROR MESSAGE	EXPLANATION
PUMP NOT FILLING	Oil not returning to vat quickly. Possible problems: dirty pad, bad or missing O-rings, tripped or defective filter pump, actuators or linkage.
DRAIN VALVE NOT OPEN	Drain valve failed to open; the valve's position is unknown.
DRAIN VALVE NOT CLOSED	Drain valve failed to close; the valve's position is unknown.
RETURN VALVE NOT OPEN	Return valve failed to open; the valve's position is unknown.
RETURN VALVE NOT CLOSED	Return valve failed to close; the valve's position is unknown.
MIB BOARD	Problem with CAN communications; check for loose CAN connections. MIB board failure.
AIF BOARD	MIB detects AIF missing; AIF board failure.
ATO BOARD	MIB detects ATO board connection lost; ATO board failure.
HIGH LIMIT FAILURE	High limit circuit has an issue.
AIF PROBE	AIF RTD reading out of range.
ATO PROBE	ATO RTD reading out of range.
TEMP PROBE FAILURE	TEMP Probe reading out of range.
MIB SOFTWARE	Internal MIB software error.
INVALID CODE LOCATION	SD card removed during update.
MISCONFIGURED ENERGY TYPE	Energy type in fryer setup is incorrect; set proper energy type gas or electric. Press 1234 to enter setup to properly configure fryer.
RTC INVALID DATE	The date is invalid. Press 1234 to enter setup to properly configure fryer and set proper date.

Automatic Filtering Fryers

FilterQuick Filter Error Flow Chart

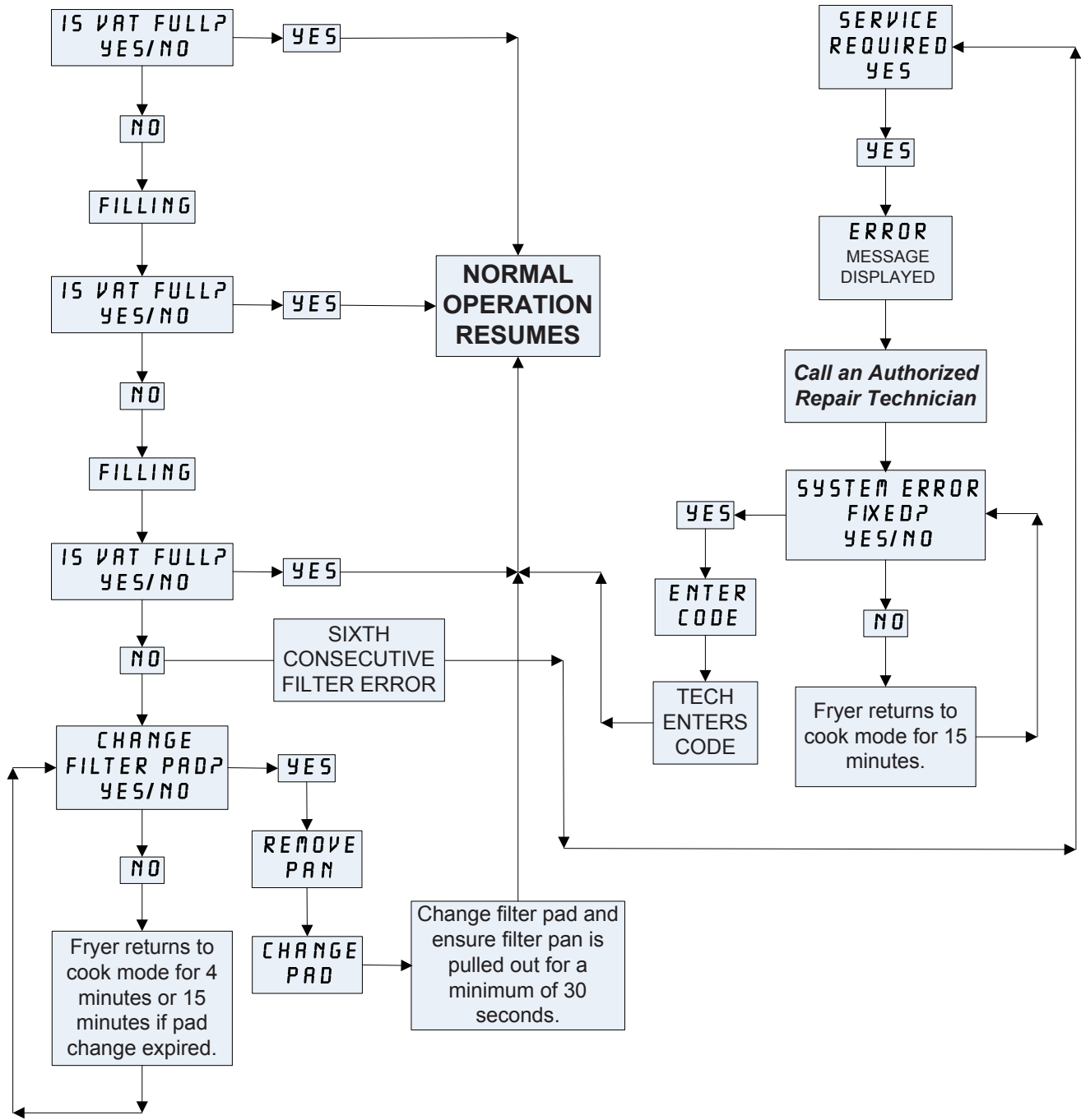

Automatic Filtering Fryers

Bulk Oil-equipped Systems

Some stores may be equipped with bulk oil storage systems. If so, some of the settings, wiring, and troubleshooting may differ from normal LOV and FilterQuick fryer systems. **The LOV and Filter-Quick fryers will ONLY operate with bulk systems that have a three-pole float switch. If the float switch is the older two-pole switch, call the bulk system provider.** The float switches are polarity specific and may short to ground and damage the MIB board.

Normal AC Voltage Measurements (MIB J6 8-pin connector with everything connected)

- Pin 1 to Pin 2 - 24 VAC.
- Pin 2 to Pin 8 - 24 VAC when waste tank is full, 0 VAC when it is not full.
- Pin 2 to Pin 3 - 24 VAC when RTI fill pump is on, 0 VAC when it is off.

Troubleshooting

The valves and pump should be off while the MIB is resetting. If any of the valves or pumps are on during reset, the MIB board is bad or wires are shorted.

Bulk oil system pump is not operating or JIB is not filling:

1. Reset the power; wait 60 seconds and see if the valve opens.

With the JIB button pressed:

2. Voltage at MIB board from Pin 1 to Pin 2 should be 24 VAC. If not, check connections from bulk system 24VAC transformer and check transformer's output.
3. Voltage at MIB board from Pin 2 to Pin 3 should be 24 VAC when filling the JIB or vat; if not, MIB board is bad or wires to pump relay are shorted or both.
4. Voltage at bulk system's add pump relay should be 24 VAC; if not, check wiring from MIB board. Check bulk system's relay.
5. Check voltage at ATO board on J8. Pin 9 to Pin 1 should be 24 VAC when the orange button is pressed.

Waste full signal: Pin 2 to Pin 8 should be 24 VAC when full, 0 VAC when not full; if there is no voltage change, then the connection from the bulk system switch or MIB board is bad.

Automatic Filtering Fryers

Disposal, Fill with RTI-equipped Systems

Bulk oil systems have large oil storage tanks, typically located in the rear of the restaurant, that are connected to plumbing at the rear of the fryer. Waste oil is pumped from the fryer through a fitting on the rear into the disposal tanks. Fresh oil is pumped from the fresh tank through another fitting.

The McDonald's and FilterQuick plumbing assemblies for the delivery of fresh oil and disposal of used oil are different. The McDonald's assembly is one-piece with a plate covering the port for the Hirschmann connector, which connects it to the wiring harness of the bulk system.

The FilterQuick plumbing is two piece. A Molex plug for the bulk wiring is on the disposal mounting bracket.

The systems have a great many similarities:

A plastic reservoir, often provided by the bulk oil supplier, replaces the cardboard surrounded-JIB in fryers without a bulk oil connection. Old oil, collected from the filter pan or another fryer, should not be added to the plastic JIB. Hot oil will damage the jug and debris in the used oil can clog the system.



Video Content
Click to Play

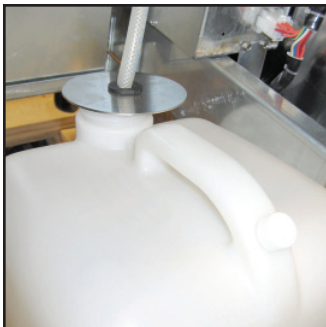

The bulk JIB with fitting.

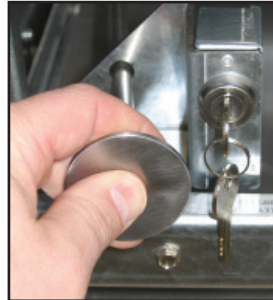

Opening the bulk disposal valve.

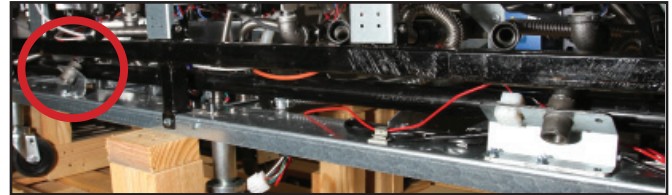

The FilterQuick bulk oil manifold is shown above and right. The fill line is on the left. The dispose is on the right next to the molex-plug,

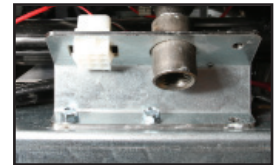

The orange JIB reset button (shown above on a McDonald's LOV fryer) is pressed to reset the system and pressed and held to refill the JIB from the bulk oil system.



The LOV bulk oil manifold is shown above and right. The fill line is on the left. The dispose is on the right next to the Hirschmann plug.



Automatic Filtering Fryers

Fryer and Bulk Oil System Plumbing Schematic

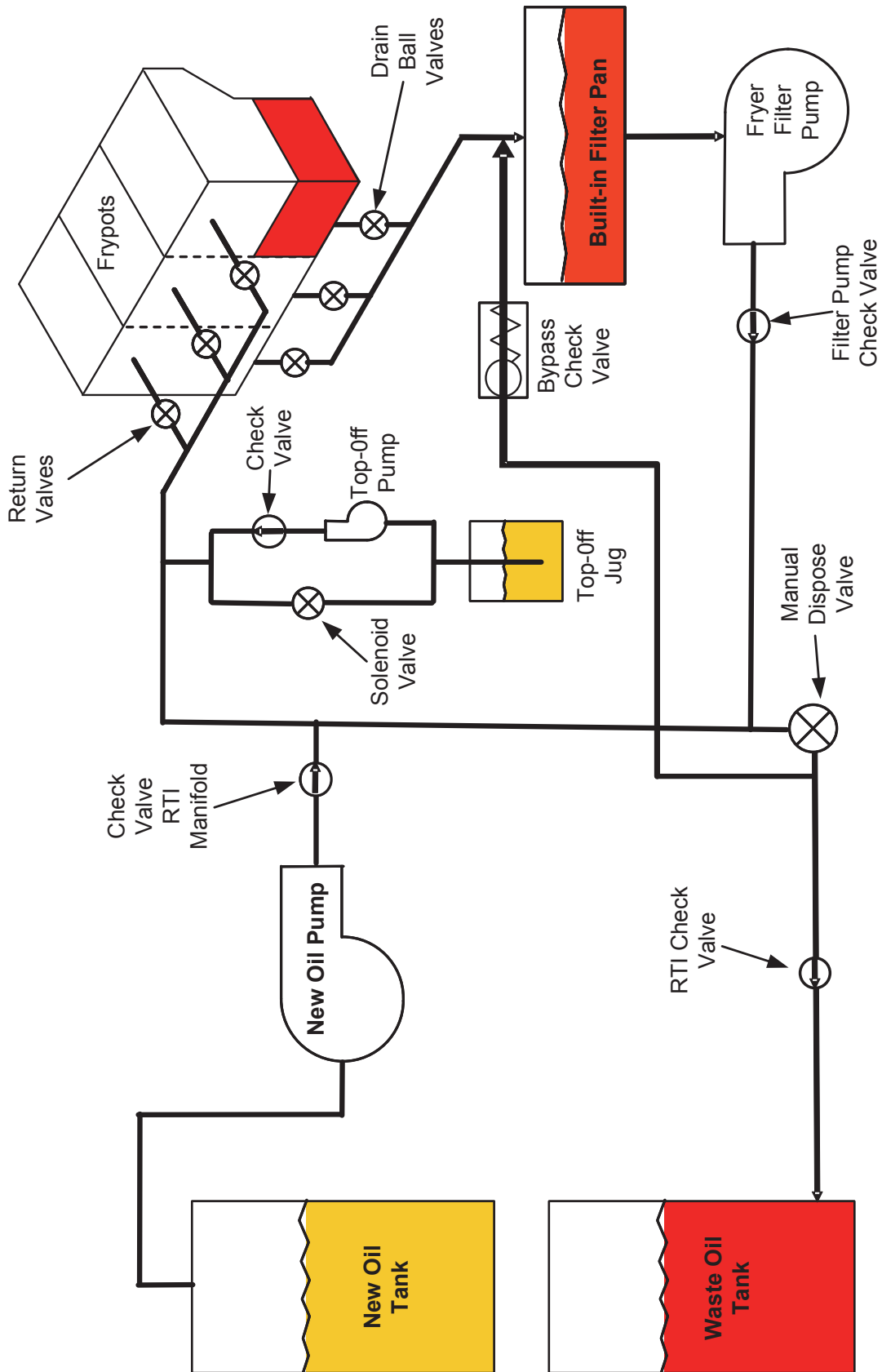

Automatic Filtering Fryers

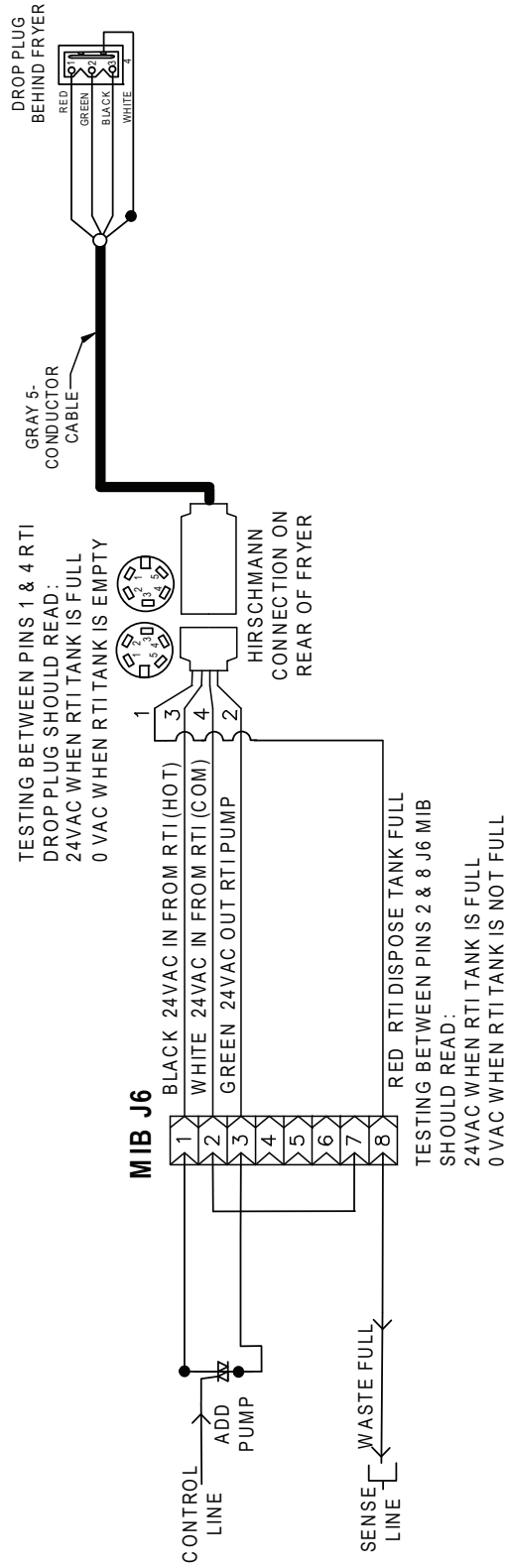

Automatic Filtering Fryers

Filter Quick

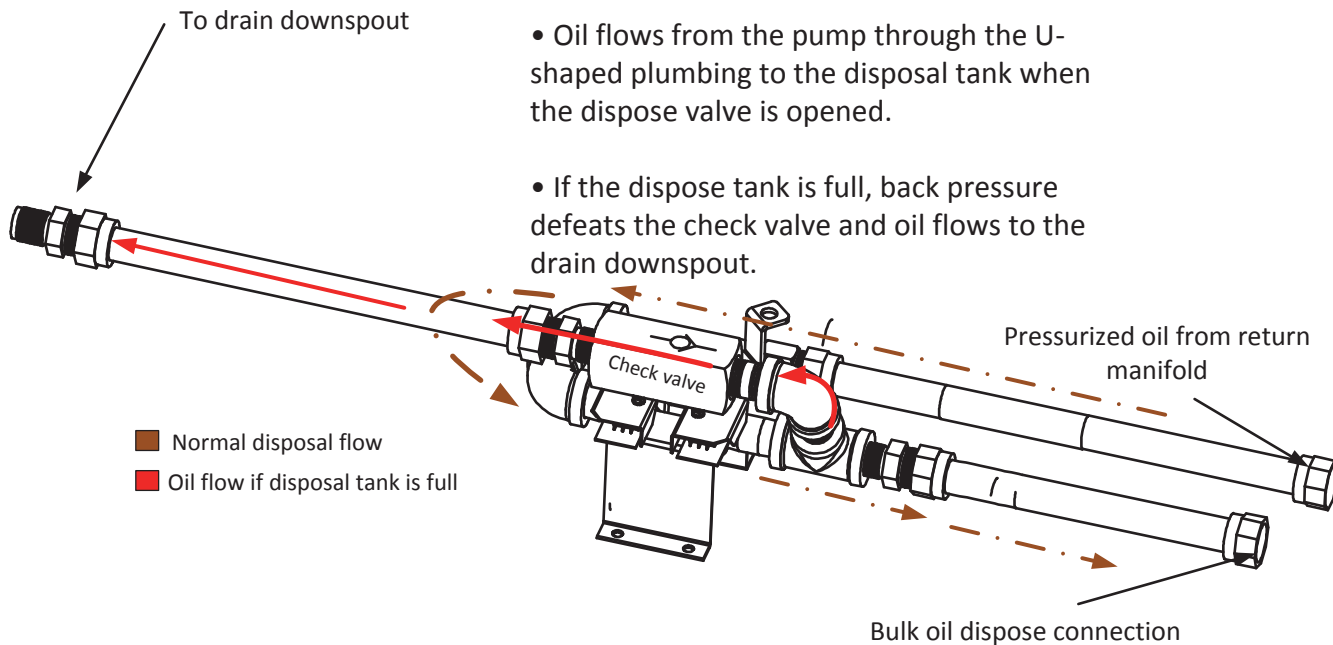

An orange momentary switch — located above the jug in the fryer cabinet in the McDonald’s unit and mounted on a bracket in the door of a FilterQuick — is used to refill the jug from the bulk system. A prompt on the FilterQuick controller notifies the user of a low JIB. On the McDonald’s unit, a bezel-mounted orange light illuminates when the JIB is low.

The controller on both fryer platforms prompts users as they navigate the oil filling and disposal operations.

A keyed lock prevents oil from being prematurely disposed.

An assembly (See above.), which feeds back to the downspout above the filter pan, protects against attempts to pump against a failed valve or a full disposal tank. Back pressure in the line, in those instances, forces open a check valve, which allows the oil to flow back to the filter pan.

Automatic Filtering Fryers

Bulk Oil FilterQuick Wiring

Testing between Pins 2 & 8 J6 MIB should read:
 24VAC When bulk tank is full.
 0 VAC When bulk tank is not full.

Testing between Pins 1 & 4
 9-Pin female plug should read:
 24VAC When bulk tank is full.
 0 VAC When bulk tank is empty.

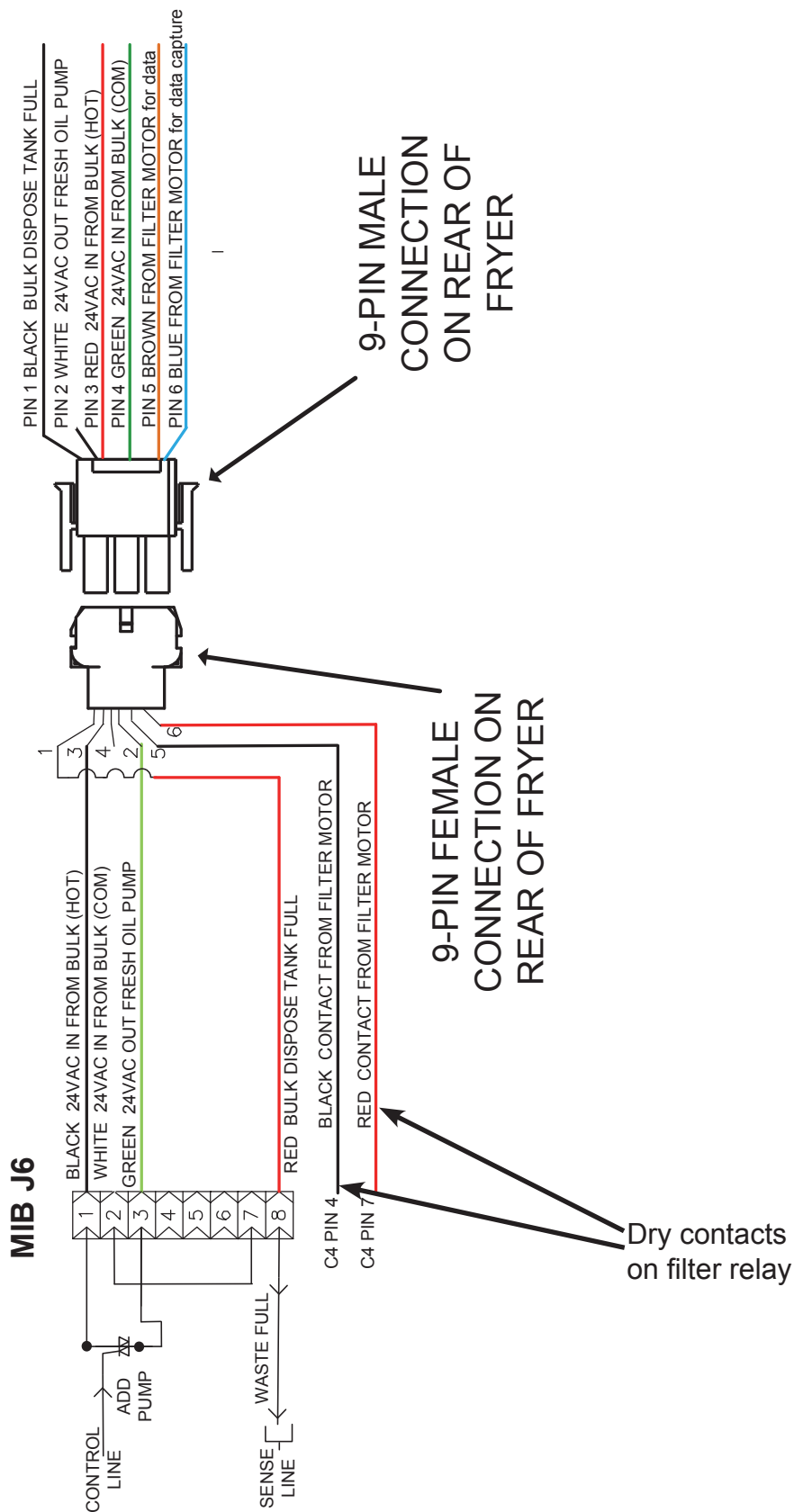

Automatic Filtering Fryers

Board and Controller Replacement

Readdress All Boards

It is necessary to readdress the system when any board or controller has been replaced or when the system has been changed from JIB to BULK oil. A readdress resets power to the entire fryer battery.

The control power reset switch is a momentary rocker switch located behind the control box, above the JIB on electric and under the far left control box on gas, that resets all power to all the controllers and boards in the fryer. Press and hold the switch for at least **15 seconds** to ensure power has sufficiently drained from boards. After releasing the momentary control power reset switch, wait at least 60 seconds before starting a function.

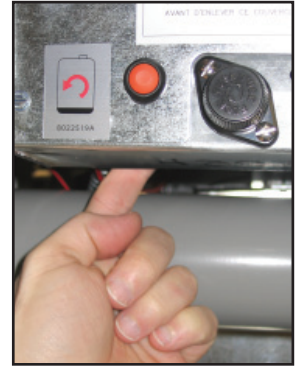

Resetting the power on an electric LOV.

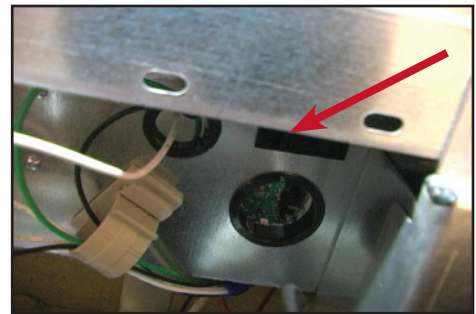

Reset switch on gas LOV.

Automatic Filtering Fryers

Special Handling for Wiring Harnesses, Connectors

The automatic filtering fryers use SMT-style connectors (Micro-Amp) for CAN connectors. The connectors are smaller, have different pin marking and require special needle probes for testing with a multi-meter.

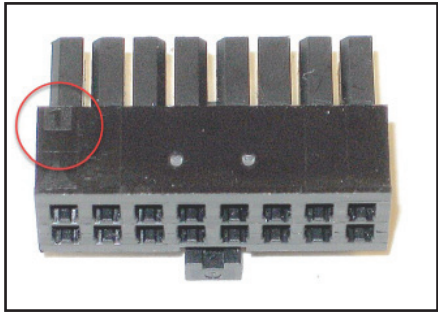

Counting Pins: With the clip at the bottom, the pins are located from left (see circled 1 pin) to right along the top row and then left to right along the bottom row.

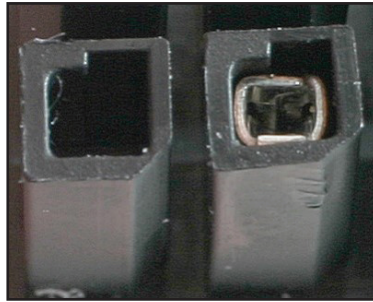

Pin Pusher: A notch in the top of the plug is for the insertion of a special pin pusher.

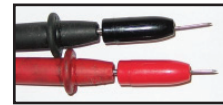

Needle Extensions: Needle extensions are needed for meter probes to test SMT plugs without damage to the connection.

Special Pin Pusher: A tool, available from Frymaster, 230-2345, is needed to push the pins in the SMT connectors.

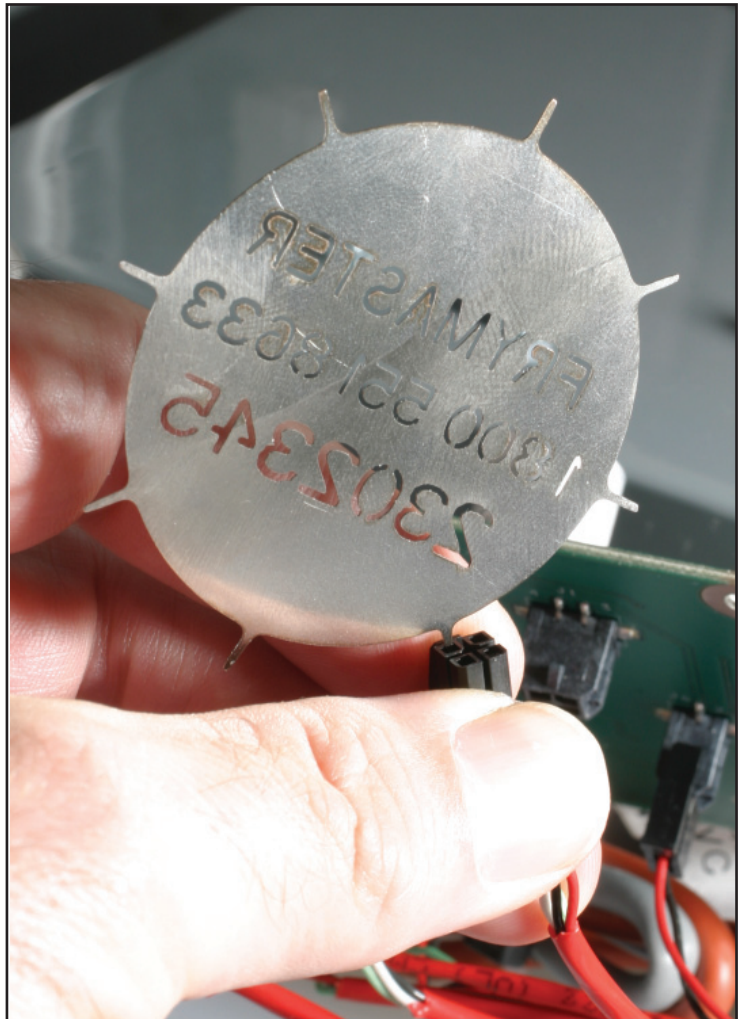

Automatic Filtering Fryers

Oil Quality Sensor

The Oil Quality Sensor, or OQS, was introduced in the fall of 2015. The sensor is in line with the flow of oil as it is filtered. The unit, available on McDonald's LOV or Filter-Quick fryers, measures total polar material (TPM's). The count, which is displayed on the controller, is a measure of the oil quality and its service life. The type of oil used in the restaurant, which effects how the readings are taken, must be entered during the setup of the controller/OQS system. The user is prompted to dispose of the oil as the TPM count goes up. The controller can display the actual TPM count or a text message, indicating oil quality.

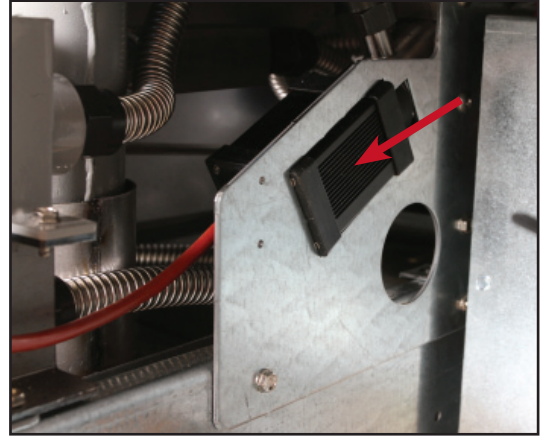

The sensor (arrow) is shown mounted adjacent and above the oil pan.

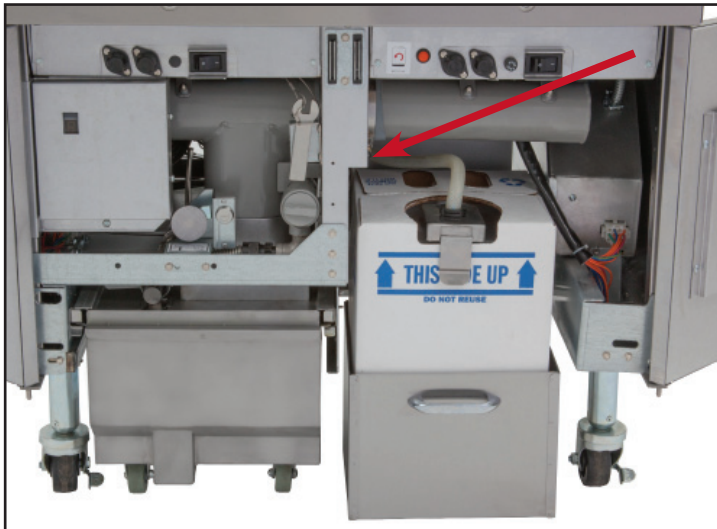

The oil sensor and its related in-line pre-filter are installed above and adjacent to the filter pan (see arrow above).



Video Content



The sensor is wired in series with the CAN bus. The existing CAN cable is disconnected from the second controller from the left and the sensor plugged in. The OQS sensor cable is shown on the right: black terminal to existing CAN; gray to controller and ground.

Automatic Filtering Fryers

Oil Quality Sensor

Troubleshooting

Problem	Corrective Action
No TPM results displayed	<p>Check the following items and perform another OQS filter.</p> <ul style="list-style-type: none"> • Ensure the vat is at setpoint temperature. • Inspect the pre-screen filter and ensure it is screwed in tightly. • Inspect the O-rings on the filter pan, and ensure they are both present and not cracked or worn. If so, replace them. • Ensure the filter paper is not clogged and clean filter paper is used. Did the vat refill the first time for the previous filter? If not change the filter paper.

Viewing OQS TPM Stats

Left Display	Right Display	Action
OFF/ON	OFF/ON	Press ▼ until Info Mode is displayed. Release
Last Dispose Stats		Press ◀ two times to scroll to TPM.
TPM		With desired stats displayed, press ▼ .
Current day	Current day	Press ▼ to view TPM.
TPM	Number/Current Day	Press ▲ ▼ to scroll for last measured TPM value that day. Press ▶ . NOTE: If OQS is not installed, or an invalid or no reading is taken, dashed lines are shown.
TPM	Number/Current Day	Press ◀ to scroll to TPM values for previous week. Press ▲ to view dates
EXIT	EXIT	Press the Scan button twice to return the controller to OFF.

Error Codes

See error codes used in the FilterQuick3000 OQS system on page 1-33.

Oil Flow Through the OQS System

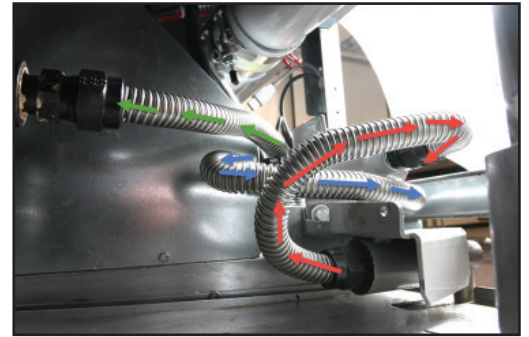
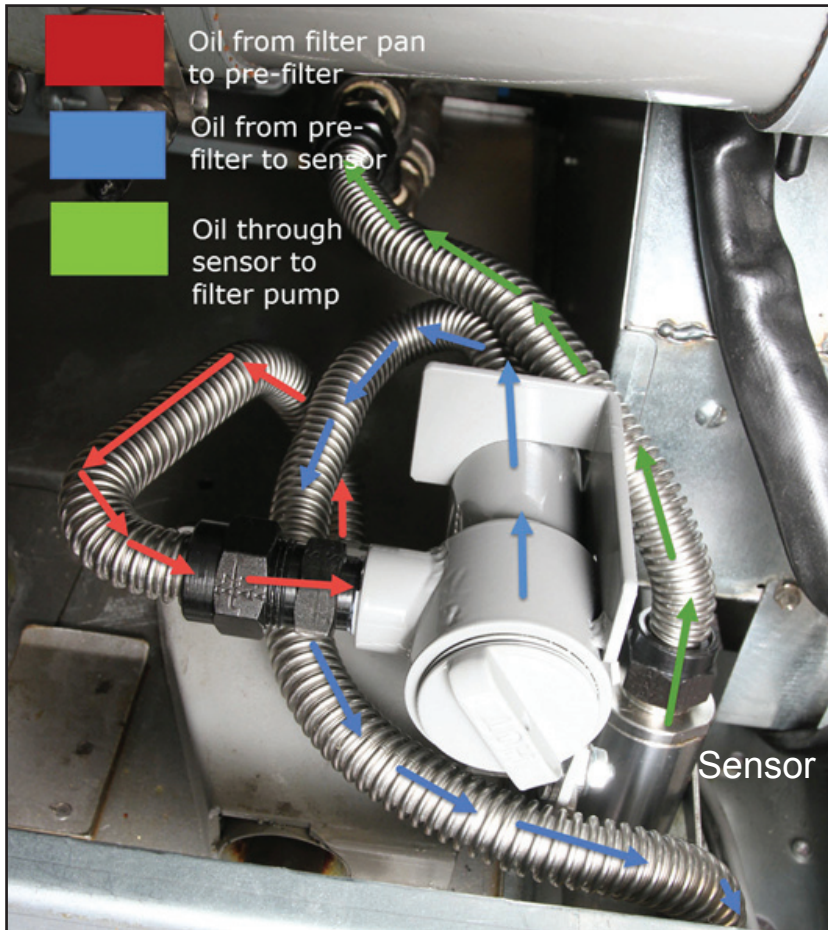

Oil flows from the filter pan (red arrows) to the in-line or pre-filter.

From there it flows to the sensor (blue arrows) to the Oil Quality Sensor.

From the sensor (green arrows) it flows to the filter pump and back to the fry pot.



The in-line filter, a line of defence for the sensor and the filter pump, (left) must be cleaned regularly. A month's worth of debris is shown in a clogged filter (center, above). A clean filter is shown right. Slow return of oil to the fry pot can often be traced to a clogged in-line filter.

Automatic Filtering Fryers

Pin Positions

LOV ATO (Automatic Top Off) Pin Positions and Harnesses

Connector	From/To	Harness #	Pin #	Function	Voltage	Wire Color	
J8	RTI Add Solenoid	8074671	1	24VAC Ret	24VAC	Black	
			2				
			3				
	ATO Pump Relay		4	24VAC Ret	24VAC	Black	
			5				
			6				
			7				
	JIB Reset Switch		8	JIB Low Reset	16VDC	Black	
	RTI Add Solenoid		9	24VAC	24VAC	Red	
			10				
			11				
	ATO Pump Relay		12	24VAC	24VAC	Red	
			13				
			14				
			15				
	JIB Reset Switch	16	Ground	16VDC	Red		
J4 (Rear) / J5 (Front)	Transformer	8074553	1	24VAC Ret	24VAC	Orange	
			2	24VAC		Blue	
			3				
			4				
			5	12VAC Ret	12VAC	Red	
			6	12VAC		Brown	
	Jumper 4 & 5 Battery		8074657	7	Jumper Wire	Ohm	Black
				8	Jumper Wire		Black
J3 - Vat #3 J2 - Vat #2 J1 - Vat #1	ATO RTD	8074655 - Vat #1 8074654 - Vat #2 8074621 - Vat #3	1	DV - Probe Ground	Ohm	White	
			2	DV - Probe		Red	
			3	FV - Probe Ground		White	
			4	FV - Probe		Red	
J6	Orange LED	8074555	1	16VDC	16VDC	Black	
			2	16VDC Ret		Red	
J7			1				
			2				
			3	Ground			
			4	RB7/DATA			
			5	RB6/CLOCK			
J10	Network Resistor (pins 2 & 3) or to next ATO Board (4 & 5 vat units)	8074552	1	Ground		Black	
			2	CAN Lo		Red	
			3	CAN Hi		White	
			4	5VDC+	5VDC	Black	
			5	24VDC	24VDC	Red	
			6	Ground		White	
J9	AIF J5	8074546	1	Ground		Black	
			2	CAN Lo		Red	
			3	CAN Hi		White	
			4	5VDC+	5VDC	Black	
			5	24VDC	24VDC	Red	
			6	Ground		White	

Automatic Filtering Fryers

LOV MIB (Manual Interface Board) Pin Positions and Harnesses

Connector	From/To	Harness #	Pin #	Function	Voltage	Wire Color	
J1	M3000 J7	8074546	1	Ground		Black	
			2	CAN Lo		Red	
			3	CAN Hi		White	
			4				
			5				
			6				
J2	AIF J4	8074547	1	Ground		Black	
			2	CAN Lo		Red	
			3	CAN Hi		White	
			4	5VDC+	5VDC	Black	
			5	24VDC	24VDC	Red	
			6	Ground		White	
J5	Transformer	8074649 RTI 8074844 NON-RTI 8074780 Gas LOV	1	24VAC	24VAC	Black	
			2	24VAC Ret		White	
	Filter Relay			3	Pump Motor	24VDC	Red
			4	Pump Motor	Green		
	Blue LED			5	Blue LED +	24VDC	Red
			6	Blue LED -	Black		
	RTI Open Switch			7	Open Switch +		Black
	RTI Closed Switch			8	Closed Switch +		Red
				9			
				10			
	Pan Switch			11	Pan Sw +	24VDC	Black
				12	Pan Sw -		Red
				13			
				14			
	RTI Open Switch			15	Ground -		White
	RTI Closed Switch			16	Ground -		Green
J6	To RTI connection in rear of fryer	8074760	1	From RTI transformer	24VAC	Black	
			2	Common		White	
			3	To RTI "Add Pump" Relay	24VAC	Green	
			4				
			5				
			6				
			7				
			8	From RTI "Waste Tank Full Sensor" Test Pins 2 to 8	24VAC – Full 0VAC – Not Full	Red	

Automatic Filtering Fryers

LOV AIF (Auto Intermittent Filtration) Actuator Board Pin Positions

Connector	From/To	Harness PN	Pin #	Function	Voltage	Wire Color	
J1	FV Return Actuator	N/A	1	Ret + (Open)	24VDC	Black	
			2	Ret – (Closed)	24VDC	Red	
			3	Ret Position		Purple	
			4	Ground		White	
J2	FV AIF RTD		1	Ground		White	
	DV AIF RTD		2	FV - Temp		Red	
			3	Ground		White	
			4	DV - Temp		Red	
			5				
			6				
			7				
			8				
			Oil Level Sensor (Gas)	9	DV – OLS (Gas)		Black
				10	FV – OLS (Gas)		Red
			Locator Pin	11	Locator Vat #5		Black
				12	Locator Vat #4		
	13	Locator Vat #3					
	14	Locator Vat #2					
	Locator	15	Locator Vat #1				
		16	Locator Signal		Black		
J3	DV Return Actuator	N/A	1	Ret + (Open)	24VDC	Black	
			2	Ret – (Closed)	24VDC	Red	
			3	Ret Position		Purple	
			4	Ground		White	
J4	MIB J2 or AIF J5	8074547 AIF Board Communication and Power	1	Ground		Black	
			2	CAN Lo		Red	
			3	CAN Hi		White	
			4	5VDC+	5VDC	Black	
			5	24VDC	24VDC	Red	
			6	Ground		White	
J5	AIF J4 or ATO J10	8074547 AIF Board Communication and Power	1	Ground		Black	
			2	CAN Lo		Red	
			3	CAN Hi		White	
			4	5VDC+	5VDC	Black	
			5	24VDC	24VDC	Red	
			6	Ground		White	
J6	FV Drain Actuator	N/A	1	Drain + (Open)	24VDC	Black	
			2	Drain – (Closed)	24VDC	Red	
			3	Drain Position		Purple	
			4	Ground		White	
J7	DV Drain Actuator	N/A	1	Drain + (Open)	24VDC	Black	
			2	Drain – (Closed)	24VDC	Red	
			3	Drain Position		Purple	
			4	Ground		White	

Automatic Filtering Fryers

LOV M3000 Board, Harnesses, and Pin Positions

Connector	From/To	Harness PN	Pin #	Function	Voltage	Wire Color
J2	Interface Board to Controller	807-4199 SMT Controller to Interface Board Harness	1	12VAC In	12VAC	Black
			2	Ground		
			3	12VAC In	12VAC	
			4	FV Heat Demand		
			5	V Relay	12VDC	
			6	DV Heat Demand		
			7	R/H B/L	12VDC	
			8	Analog Ground		
			9	L/H B/L	12VDC	
			10	ALARM		
			11	Sound Device	5VDC	
			12	ALARM		
			13	FV Probe		
			14	Common Probes		
			15	DV Probe		
			J6	Next M3000 J7 or Network Resistor	807-4546 Controller Communication Harness	
2	CAN Lo					Red
3	CAN Hi					White
4						
5						
6						
J7	MIB J1 or previous M3000 J6	807-4546 Controller Communication Harness	1	Ground		Black
			2	CAN Lo		Red
			3	CAN Hi		White
			4			
			5			
			6			
J9	ONLY USED ON NON-AIF UNITS					
J10	Interface Board Ground to Controller	807-4573 Controller Locator Harness	1	Vat #1		Black
			2	Vat #2		
			3	Vat #3		
			4	Vat #4		
			5	Vat #5		
			6			
J11	SD Card					

Automatic Filtering Fryers

FilterQuick ATO (Automatic Top Off) Pin Positions and Harnesses

Connector	From/To	Harness #	Pin #	Function	Voltage	Wire Color			
J8	Bulk Fresh Oil Solenoid	8074671	1	24VAC Ret	24VAC	Black			
			2						
			3						
	Top Off Pump Relay		4	24VAC Ret	24VAC	Black			
			5						
			6						
			7						
	JIB Reset Switch		8	JIB Low Reset	16VDC	Black			
	Bulk Fresh Oil Solenoid		9	24VAC	24VAC	Red			
			10						
			11						
	Top Off Pump Relay		12	24VAC	24VAC	Red			
			13						
			14						
			15						
			JIB Reset Switch	16	Ground	16VDC	Red		
J4 (Rear) / J5 (Front)	Transformer	8074553	1	24VAC Ret	24VAC	Orange			
			2	24VAC		Blue			
				3					
				4					
				5	12VAC Ret	12VAC	Red		
				6	12VAC		Brown		
				ATO 4 & 5 Battery Jumper	8074657	7	Jumper	Ohm	Black
				8		Jumper	Ohm	Black	
J1 - Vat #1 J2 - Vat #2 J3 - Vat #3	ATO RTD	8262569- Probe Kit, 8074845 – 28" Ext., 8074655 – 20" Ext.,	1	DV - Probe Ground	Ohm	White			
			2	DV - Probe		Red			
			3	FV - Probe Ground		White			
			4	FV - Probe		Red			
J6									
J10	Network Resistor (pins 2 & 3) or to next ATO Board (4 & 5 vat units)	8074552 (Network resistor), 8074546 to next ATO board	1	Ground		Black			
			2	CAN Lo		Red			
			3	CAN Hi		White			
			4	5VDC+	5VDC	Black			
			5	24VDC	24VDC	Red			
			6	Ground		White			
J9	AIF J5	8074547	1	Ground		Black			
			2	CAN Lo		Red			
			3	CAN Hi		White			
			4	5VDC+	5VDC	Black			
			5	24VDC	24VDC	Red			
			6	Ground		White			

Automatic Filtering Fryers

FilterQuick MIB (Manual Interface Board) Display Diagnostics

Connector	From/To	Harness #	Pin #	Function	Voltage	Wire Color	
J1	FilterQuick™ Controller/ J6	8074546	1	Ground		Black	
			2	CAN Lo		Red	
			3	CAN Hi		White	
			4				
			5				
			6				
J2	AIF J5	8074850	1	Ground		Black	
			2	CAN Lo		Red	
			3	CAN Hi		White	
			4	5VDC+	5VDC	Black	
			5	24VDC	24VDC	Red	
			6	Ground		White	
J5	Transformer	8075800 Bulk	1	24VAC In	24VAC	Black	
			2	24VAC In Ret		White	
	Filter Relay	8075780 Non-Bulk	3	Pump Motor + Out	24VDC	Red	
				4		Pump Motor - Out	Green
				5			
				6			
	Bulk Open Switch			7	Open Switch +		Black
	Bulk Closed Switch			8	Closed Switch +		Red
				9			
				10			
	Pan Switch			11	Pan Sw +	24VDC	Black
				12	Pan Sw -		Red
			13				
			14				
	Bulk Open Switch		15	Ground -		White	
	Bulk Closed Switch		16	Ground -		Green	
J6	To Bulk connection in rear of fryer	8075789	1	From bulk oil trans- former	24VAC	Black	
			2	Common Return		White	
			3	To bulk oil fresh oil pump relay	24VAC	Green	
			4				
			5				
			6				
			7				
			8	From bulk oil "Waste Tank Full Sensor" Test Pins 2 to 8	24VAC – Full 0VAC – Not Full	Red	

Automatic Filtering Fryers

FilterQuick AIF (Auto Intermittent Filtration) Actuator Board Pin Positions

Connector	From/To	Harness #	Pin #	Function	Voltage	Wire Color
J1	FV Return	N/A	1	Ret + (Open)	24VDC	Black
			2	Ret – (Closed)	24VDC	Red
			3	Ret Position		Blue
			4	Ground		White
J2	FV AIF RTD	N/A	1	Ground		Red
	DV AIF RTD		2	FV - Temp		White
			3	Ground		Red
	Oil Level Sensor (Gas)		4	DV - Temp		White
			5	OIB Sensor FV from Pin 5 on J3 of Interface Bd	12VDC	Red
			6	OIB Sensor FV		Black
			7	OIB Sensor DV from Pin 5 on J3 of Interface Bd	12VDC	Red
	Oil Level Sensor communication (Gas)		8	OIB Sensor DV		Black
			9	DV – OLS (Gas)		Black
	Locator Pin		10	FV – OLS (Gas)		Red
			11	Locator Vat #5		Black
			12	Locator Vat #4		
			13	Locator Vat #3		
			14	Locator Vat #2		
	15		Locator Vat #1			
	Locator		16	Locator Signal		Black
J3	DV Return	N/A	1	Ret + (Open)	24VDC	Black
			2	Ret – (Closed)	24VDC	Red
			3	Ret Position		Blue
			4	Ground		White
J4	MIB J2 or AIF J5	8074547	1	Ground		Black
		AIF Board Communication and Power	2	CAN Lo		Red
			3	CAN Hi		White
			4	5VDC+	5VDC	Black
			5	24VDC	24VDC	Red
			6	Ground		White
J5	AIF J4 or ATO J10	8074547	1	Ground		Black
		AIF Board Communication and Power	2	CAN Lo		Red
			3	CAN Hi		White
			4	5VDC+	5VDC	Black
			5	24VDC	24VDC	Red
			6	Ground		White
J6	FV Drain	N/A	1	Drain + (Open)	24VDC	Black
			2	Drain – (Closed)	24VDC	Red
			3	Drain Position		Blue
			4	Ground		White
J7	DV Drain	N/A	1	Drain + (Open)	24VDC	Black
			2	Drain – (Closed)	24VDC	Red
			3	Drain Position		Blue
			4	Ground		White

Automatic Filtering Fryers

FilterQuick 3000 Board, Harnesses, and Pin Positions

Connector	From/To	Harness PN	Pin #	Function	Voltage	Wire Color
J1	SD Card					
J2	Interface Board to Controller	8075165 SMT Controller to Interface Board Harness	1	12VAC In	12VAC	Orange
			2	Ground		
			3	12VAC Return In	12VAC	
			4	FV Heat Demand		
			5	V Relay	12VDC	
			6	DV Heat Demand		
			7	R/H B/L	12VDC	
			8	Analog Ground		
			9	L/H B/L	12VDC	
			10	ALARM		
			11	Sound Device	5VDC	
			12	ALARM		
			13	FV Probe		
			14	Common Probes		
			15	DV Probe		
			16			
			17			
			18			
			19	Blower Cool Down Ground		
			20			
J3	Interface Board Ground to Controller	Controller Locator Harness	1	Vat #1		Black
			2	Vat #2		
			3	Vat #3		
			4	Vat #4		
			5	Vat #5		
			6	Ground		
J4	Drain Switch and LED	1085672	1	Ground		Black
			2	Push Pull Switch In		Red
			3	Ground		Black
			4	Drain Indicator LED		Red
J6	Next Controller J7 or Network Resistor	8074546 Controller Communication Harness	1	Ground		Black
			2	CAN Lo		Red
			3	CAN Hi		White
			4			
			5			
			6			
J7	MIB J1 or previous Controller J6	8074546 Controller Communication Harness	1	Ground		Black
			2	CAN Lo		Red
			3	CAN Hi		White
			4			

Automatic Filtering Fryers



LOV™ FRYER COMMISSION AND DEMONSTRATION FORM

8700 LINE AVENUE SHREVEPORT, LA 71106 (800) 551-8633



Date _____

Store Name _____
 Store # (if applicable) _____
 Address _____
 City/State _____
 Store Phone () _____

Technician _____
 Service Agency _____
 Address _____
 City/State _____
 Country _____

FRYER/FILTER MODEL NUMBER	SERIAL NUMBER (10 DIGIT)

- No one is to perform start-up or training unless they are Level 2 or Level 3 certified and their certification is current.**
- Verify exhaust blank-off plates are installed with Electric Fryers YES NO N/A (GAS)
- Verify Universal hoods have 2" (50mm) of clearance behind fryer YES NO
- Verify Seal Angle, Stand-off Channel & Gravity Blade are properly installed YES NO N/A (Universal Hood)
- Verify gas hose quick disconnect is connected to gas line input beneath the center of the fryer and verify the left gas input connection is properly capped.
- Remove Warranty Label date tabs.
- Ensure fryer is level and properly restrained in accordance with the operator's manual.
- Perform SETUP on all computers. Refer to manual. **Record Software Controller** _____
MIB _____ **AIF** _____ **ATO** _____ **OQS (if applicable)** _____
- Ensure Time and Date are correct in setup.**
- Verify Filter After settings in Level 2 are set to 12 for Fry Stations and 6 for Protein Stations.
- Program computers for products to be cooked as per managers request - FR FRIES, HASH BRN, NUGGETS, MCCHICK, etc. Refer to manual. Attach product stickers to bezel **below** product buttons.
- Is the fry system being installed connected to a **BULK OIL SUPPLY / DISPOSAL SYSTEM (RTI)** YES NO
- If fryer was setup as a **BULK OIL SUPPLY / DISPOSAL SYSTEM (RTI)** was power cycled after setup? YES NO
- Is the gas restraining kit installed on the fryer? YES NO
- Place full JIB in fryer for ATO system, or fill provided JIB from Bulk Oil system (as applicable). Refer to manual.
- Thoroughly clean and dry all vats. Fill all vats with oil to 1/2" below cold oil line. Allow fryers to heat to set point (see gas and electric checks below) and verify temperatures are at set point +/- 5°F / 2°C. **Verify that oil level is below ATO level sensor (upper oil level line) but above AIF sensor (lower oil level) (add/remove oil if necessary) and that each vat tops off from JIB.**
- Check restaurant to ensure that it doesn't have a severe positive or negative air balance.
- GAS** fryers - While units are heating up, check incoming gas pressure (Natural Gas: 6-14" W.C.; LP Gas: 11-14" W.C.). Record actual incoming pressure _____. Check burner manifold pressure. Record actual burner manifold pressure below. Check for proper combustion; fryers should have a bright orange flame after approximately 1 minute of operation. Adjust blower air inlet to achieve 1.2 - 2.0 uA (micro amps) on Fenwal Modules or .3 - .9 uA on Capable Control Modules on each igniter flame sense circuit. Record micro amp readings below.

Gas	Vat #1	Vat #2	Vat #3	Vat #4	Vat #5	Vat #6	Vat #7	Vat #8	Vat #9	Vat #10
Burner Pressure										
Left uA										
Right uA										

Two (2) hours are allowed for Commission per fryer system; fry or protein station. Two (2) hours are allowed for one (1) Demonstration per store location.

Continued on next page

Automatic Filtering Fryers



- ELECTRIC** fryers - While units are heating up, ensure applied voltage matches the rating plate. Ensure all phases are balanced and there is no current draw when controller heat light is off.

AMP DRAW										
Electric	Vat #1	Vat #2	Vat #3	Vat #4	Vat #5	Vat #6	Vat #7	Vat #8	Vat #9	Vat #10
L1										
L2										
L3										

- Verify that all filter parts (filter pan, filter screen, filter pad or paper, hold-down ring, crumb tray, and O-rings) are present. Visually inspect the oil drain and return system to ensure all connections are tight.
- Verify filter pan alignment. The pan should slide smoothly into position with an “A” displayed on the MIB. Ensure pick-up tube is fully engaged in the pan suction tube. “P” should be displayed on the MIB when the pan is pulled forward.
- Perform an Auto Filter on a vat to ensure the filter pump is operational and check the drain and return system for leaks. If OQS is installed, TPM value. _____
- Remove old Fryer’s Friend from the store and replace with the new Fryer’s Friend.**
- The startup tech is responsible for training the operators following the steps below.

LOV™ Fryer Training

Ensure all trainees refer to the Quick Reference, Quick Start, Fry Guides and Operation Manual located in the manual holder inside the fryer door for the following.

Hands on demonstration and performance are essential for all trainees.

CREW / FILTRATION PERSON(S) / MANAGERS

- OVERVIEW**
 - Provide an overview of what a LOV is Vs traditional fryer – Smaller vat, Low Oil Volume
 - Explain the benefits when used properly – Use less oil, Auto Filter, Auto Top Off
- COMPUTER**
 - Identify M3000 Computer buttons and functions / LED’s for LOV – Refer to the LOV Quick Start Guide**
 - ON / OFF Buttons – Full and Split Functions
 - Product Buttons - Multi product cooking buttons and entering codes for programming
 - Cook Cycle Buttons – Start a cook cycle / cancel alarms and change from Dedicated to Multi Product
 - Filter Buttons – On- Press -Cooks Remaining / On = Press and hold to access Filter Menu / Menu navigation
 - Temp Button – Off – Versions of software / On = 1(X) actual temp 2(X) set-point
 - Info Button – 1(X) Recovery check of fryer / Press and hold 3 seconds = Filter Stats, Usage, Last Load
 - Filter Light Blue LED
 - JIB Orange LED / JIB Reset
 - Master Power Switch (per vat) (US ONLY)
 - MIB Display Window – “A” for Auto or “P” filter pan installation issue. Check for proper installation of pan.
 - Demonstrate how to use the operating controls – Cooking Functions – Refer to the LOV Fryer Station Guides**
 - Turning the computer ON / OFF for heating the vats
 - One button cooking – Dedicated Mode - **Refer to the LOV Fry Station Guide (French Fries/Hashbrowns)**
 - Two button cooking – Multi Product. Show **REMOVE DISCARD PRODUCT** message if setpoint is different for product being cooked. - **Refer to the LOV Fry Station Guide (McNuggets, Crispy, etc.)**
 - Changing from breakfast to lunch and back
 - Cancel a cook cycle or alarms
 - Demonstrate JIB System (JIB and Bulk Oil Systems) – Refer to the LOV Quick Reference Guide**
 - Demonstrate setup of the JIB
 - Filling vats with oil (Bulk or JIB)
 - AUTO TOP-OFF (ATO) – Refer to the LOV Quick Reference Guide**
 - Instruct on function of Yellow “JIB Empty” LED (Use remaining oil in box)

Automatic Filtering Fryers



- Demonstrate when JIB is changed JIB reset must be pressed and held to reset light
- Demonstrate Auto Top-Off on a vat by moving oil out of vat

AUTOMATIC INTERMITTENT FILTRATION (AIF) – Refer to the LOV Quick Reference Guide

- Demonstrate assembly of the filter pan (Emphasize need for daily pad change / more often as needed)
- Demonstrate AIF cycle on “TEST” menu item. Air bubbles should only be observed in unit being filtered.
- Show Blue LED, SAY “YES” TO THE BLUE LIGHT
- Show “FILTER NOW” displayed on vat to be filtered
- Demonstrate new skimming procedure
- Show filtration issues (OIL TOO LOW, errors created by not changing the pad (monitor oil returned to vat levels – should be where it started)
- Show FILTER BUSY message by trying to manual filter while another vat is filtering.
- Six consecutive unsuccessful filtrations and unit goes to **SERVICE REQUIRED** an authorized technician is needed.
- Show location of thermal reset on Filter Motor

TROUBLESHOOTING

- Common error messages
 - Is Vat Full? – a problem may exist in the filtration system – Follow instructions on the computer.
 - Drain Clogged- Clear Drain-Is Drain Clear? (Gas Only) – Follow instructions on the computer using the new fryers friend to clear the drain.
 - Filter Busy – a filtration process is in another vat
 - Probe Failure – Temperature circuitry has a problem – Turn off fryer and call for service
 - Heating Failure – Unit is not heating – Turn off fryer and turn on again.
 - Low Temp – Oil temperature below set point – may occur during cooking cycle
 - Recovery Fault – Vat did not meet minimum specs for temperature recovery – Press the ✓ to continue.
 - Service Required – a problem exists that requires a technician.
- Frymaster’s Hot line and ASA contact person / with phone numbers

FILTRATION PERSON(S) / MANAGERS

Refer to LOV Quick Reference Guide and Operations Manual Chapter 4

- Demonstrate daily cleaning of the oil sensor during maintenance filters with no-scratch pad (gas only).
- FILTER MENU (Press and hold LEFT or RIGHT FLTR button based on the type of vat being filtered)

NON BULK OIL SYSTEM

- Demonstrate how to access FILTER MENU
 - Show AUTO FILTER and explain what it does
 - Show MAINT FLTR (**always filter the Fish vat last**)
 - Show DISPOSE and explain what it does (Use of MSDU)
 - Show DRAIN TO PAN and explain what it does
 - Show FILL VAT FROM DRAIN PAN and explain what it does

BULK OIL SYSTEM

- Demonstrate how to access FILTER MENU
 - Show AUTO FILTER and explain what it does
 - Show MAINT FLTR (**always filter the Fish vat last**)
 - Show DISPOSE and explain what it does
 - Show DRAIN TO PAN and explain what it does
 - Show FILL VAT FROM DRAIN PAN and explain what it does
 - Show FILL VAT FROM BULK and explain what it does
 - Show PAN TO WASTE and explain what it does

Automatic Filtering Fryers



STORE MANAGERS ONLY (OR DESIGNATED PERSONS)

Refer to LOV Quick Start Guide and Operations Manual Chapter 4

- Demonstrate how to access LEVEL 1 PROGRAMMING – (Press and hold TEMP and INFO) Code 1234**
 - Demonstrate Product Selection and setting up an item and Assigning Buttons
 - Demonstrate how to add a new Menu Item – setup a test menu item (short cook cycle)
 - Deep Clean
 - High Limit Check
 - Fryer Setup Mode
- Demonstrate how to access LEVEL 2 PROGRAMMING – (Press and hold TEMP and INFO) Code 1234**
- Demonstrate how to access INFO MODE (Press and hold INFO for three seconds)**
 - Show FILTER STATS menu
 - Show REVIEW USAGE menu
 - Show LAST LOAD menu
- Demonstrate Deep Clean Procedures – as much as practical (Refer to Operations Manual Chapter 4)**

Key Points

Review with all employees

- **Blue Light – Choose YES to Filter Now? and Confirm**
- **Orange Light – Change JIB and press reset (Bulk users fill JIB)**
- **Start a cook on the fry station by pressing the cook button**
- **Start a cook on the protein station by pressing the product button and then the cook button.**
- **Is Vat Full? – Answer YES only when oil it at the top line.**
- **Maintenance filter daily**
- **Change filter pad daily or twice daily in high volume or 24 hour stores**

Date of Training _____

Training has been conducted on the following areas:

- | | |
|--------------------------------|----------------------------------|
| 1) Computer functions | 6) Level 1 Programming |
| 2) Operating the Fryer | 7) Level 2 Programming |
| 3) JIB System | 8) Accessing Info Mode |
| 4) Auto Top Off | 9) Explain Deep Cleaning Process |
| 5) Auto Filter and Filter Menu | 10) Troubleshooting |

Training / Demo Signature Sheet – Key Personnel

* Store Manager's Signature		Printed Name	
* Filtration Person Signature		Printed Name	
* Key Shift Person Signature		Printed Name	

Automatic Filtering Fryers



O/O / Staff Personnel		Printed Name	
--------------------------	--	-----------------	--

Technician's Signature		Printed Name	
---------------------------	--	-----------------	--

* - Mandatory Attendee

TRAINING DECLINED

O/O / Corporate Manager Signature		Printed Name	
--------------------------------------	--	-----------------	--

FAS: Provide a copy of all five (5) pages to the customer and to Frymaster. Retain a copy for two years from date of installation

Automatic Filtering Fryers



FILTERQUICK™ FRYER START-UP FORM

8700 LINE AVENUE SHREVEPORT, LA 71106 (800) 551-8633

Date _____

Store Name _____
 Store # (if applicable) _____
 Address _____
 City/State _____
 Store Phone () _____

Technician _____
 Service Agency _____
 Address _____
 City/State _____
 Country _____

FRYER/FILTER MODEL NUMBER	SERIAL NUMBER (10 DIGIT)

- No one is to perform start-up or training unless they are Level 3 certified and their certification is current.**
- Verify gas hose quick disconnect is connected to gas line input beneath the center of the fryer and verify the left gas input connection is properly capped.
- Remove Warranty Label date tabs.
- Ensure fryer is level and properly restrained in accordance with the operator's manual.
- Perform SETUP on all computers. Refer to manual.
- Record Software Controller _____ MIB _____ AIF _____
 ATO _____ OQS(if applicable) _____
- Ensure Time and Date are correct in setup.**
- Program controllers for products to be cooked as per managers request - Refer to controller manual.
- Is the fry system being installed connected to a **BULK OIL SUPPLY / WASTE DISPOSAL SYSTEM** YES NO
- If fryer was setup as a **BULK OIL SUPPLY / WASTE DISPOSAL SYSTEM** was power cycled after setup? YES NO
- Place full JIB in fryer for ATO system, or fill provided JIB from Bulk Oil system (as applicable). Refer to controller manual.
- Thoroughly clean and dry all vats. Fill all vats with oil to ½" below cold oil line. Allow fryers to heat to set point (see gas and electric checks below) and verify temperatures are at set point +/- 5°F / 2°C. **Verify that oil level is below ATO level sensor (upper oil level line) but above AIF sensor (lower oil level) (add/remove oil if necessary) and that each vat tops off from JIB. NOTE: HEAT LED must cycle 3 times before top off is activated.**
- Check restaurant to ensure that it doesn't have a severe positive or negative air balance.
- GAS** fryers - While units are heating up, check incoming gas pressure (Natural Gas: 6-14" W.C.; LP Gas: 11-14" W.C.). Record actual incoming pressure _____. Check burner manifold pressure. Record actual burner manifold pressure below. Check for proper combustion; fryers should have a bright orange flame after approximately 1 minute of operation. Adjust blower air inlet to achieve 1.2 - 2.0 uA (micro amps) on Fenwal Modules or .3 - .9 uA on Capable Control Modules on each igniter flame sense circuit. Record micro amp readings below.

Gas	Vat #1	Vat #2	Vat #3	Vat #4	Vat #5	Vat #6	Vat #7	Vat #8	Vat #9	Vat #10
Burner Pressure										
Left uA										
Right uA										

- ELECTRIC** fryers - While units are heating up, ensure applied voltage matches the rating plate. Ensure all phases are balanced and there is no current draw when controller heat light is off.

AMP DRAW										
Electric	Vat #1	Vat #2	Vat #3	Vat #4	Vat #5	Vat #6	Vat #7	Vat #8	Vat #9	Vat #10
L1										
L2										
L3										

- Verify that all filter parts (filter pan, filter screen, filter pad or paper, hold-down ring, crumb tray, and O-rings) are present. Visually inspect the oil drain and return system to ensure all connections are tight.
- Verify filter pan alignment. The pan should slide smoothly into position with an "A" displayed on the MIB. Ensure pick-up tube is fully engaged in the pan suction tube. "P" should be displayed on the MIB when the pan is pulled forward.

Two (2) hours are allowed for the above to Start-Up one system.

8197129
04/2018

Automatic Filtering Fryers



- Perform an Auto Filter or OQS Filter (if applicable) on a vat to ensure the filter pump is operational and check the drain and return system for leaks. If OQS is installed, TPM value/Oil is Good _____
- Remove old Fryer's Friend from the store and replace with the new Fryer's Friend**
- The startup tech is responsible for training the operators following the following the steps below.

FILTERQUICK™ FRYER TRAINING

Ensure all trainees refer to the Quick Reference, Quick Start, Controller Manual and Operation Manual located in the manual holder inside the fryer door for the following.

Hands on demonstration and performance are essential for all trainees.

CREW / FILTRATION PERSON(S) / MANAGERS

- OVERVIEW**
 - Provide an overview of what a FilterQuick is vs. traditional fryer – Smaller vat, Low Oil Volume
 - Explain the benefits when used properly – Use less oil, Semi-automatic Filter, Auto Top Off
- CONTROLLER**
 - Identify FilterQuick™ Controller buttons and functions / LED's for filtration – Refer to the FilterQuick™ Quick Start Guide**
 - ON / OFF Buttons — Demonstrate full and split functions.
 - Cook Cycle Buttons — Demonstrate a cook cycle/stop a cook cycle.
 - Exit Cool Button — Demonstrate entering and exiting the energy-saving Cool Mode.
 - Temp Button — Demonstrate Use: **ON** – Setpoint and vat temperature; **OFF** – Temp, time, date, software versions.
 - Checkmark Button — Demonstrate Use: **ON** – Enter codes, respond to prompts; **OFF** – Press and hold 3 seconds: Scroll filter usage.
 - Filter Button — Demonstrate Use: Press and release: Cooks remaining or percentage and cooks remaining to filter prompt; Press and hold: Filter options.
 - Exit Scan — Demonstrate Use: Scan programmed menu items and exit menus.
 - JIB Reset switch / Bulk fill switch on bulk fresh oil systems
 - Master Power Switch (per vat) (Electric and US ONLY)
 - MIB Display Window – “A” for Auto or “P” filter pan installation issue. Check for proper installation of pan.
 - Reset switch (Behind control box in far right Electric fryers, under control box in far left Gas fryers)
 - Demonstrate JIB System (JIB and Bulk Oil Systems) – Refer to the FilterQuick™ Quick Start Guide and the Installation and Operation Manual**
 - Demonstrate setup of the JIB
 - Filling vats with oil (Bulk or JIB)
 - AUTO TOP-OFF (ATO) – Refer to the FilterQuick™ Quick Start Guide and the Installation and Operation Manual**
 - Instruct on function Top Off Oil Empty Display.
 - Demonstrate pressing and holding the JIB reset button after JIB replacement will clear the top off empty message and reset the top off system
 - Demonstrate Auto Top-Off on a vat by moving oil out of vat.
 - FILTRATION – Refer to the FilterQuick™ Quick Start Guide and the Installation and Operation Manual**
 - Demonstrate assembly of the filter pan (Emphasize need for daily filter paper/pad change / more often as needed)
 - Demonstrate FILTER. Show “FILTER NOW” displayed on vat to be filtered. Explain YES and NO responses. Air bubbles should only be observed in unit being filtered.
 - Show filtration issues (OIL TOO LOW – Oil level is too low to filter; Errors created by not changing the paper/pad (monitor oil returned to vat levels – should be where it started)
 - Show FILTER BUSY message by trying to filter or perform a filter menu function while another vat is filtering.

Automatic Filtering Fryers



- Show location of thermal reset on Filter Motor
- Have filter prompts been added or demonstrated?

TROUBLESHOOTING

- Common error messages
 - Is Vat Full? – a problem may exist in the filtration system – Follow instructions on the controller to ensure any or all oil is returned from the filter pan.
 - Drain Clogged- Clear Drain-Is Drain Clear? (Gas Only) – Follow instructions on the controller using the new fryers friend to clear the drain.
 - Filter Busy – a filtration process is in another vat
 - Probe Failure – Temperature circuitry has a problem – Turn off fryer and call for service
 - Heating Failure – Unit is not heating – Turn off fryer and turn on again.
 - Low Temp – Oil temperature below set point – may occur during cooking cycle
 - Recovery Fault – Vat did not meet minimum specs for temperature recovery – Press the YES button to continue.
 - Service Required – a problem exists that requires a technician.
- Frymaster's Hot line and FAS contact person / with phone numbers

FILTRATION PERSON(S) / MANAGERS

Refer to Refer to the FilterQuick™ Quick Start Guide and the FilterQuick™ Controller Manual Chapter 1

- Demonstrate daily cleaning of the oil sensor during Clean and Filter with no-scratch pad (gas only).

FILTER MENU (Press and hold FILTER button)

NON BULK OIL SYSTEM

Demonstrate how to access FILTER MENU

- Show FILTER and explain what it does
- Show CLEAN and FILTER (clean oil sensor on gas units)
- Show DISPOSE and explain what it does (Use of SDU)
- Show DRAIN TO PAN and explain what it does
- Show BOIL OUT and explain what it does
- Show FILL VAT FROM PAN and explain what it does

BULK OIL SYSTEM

Demonstrate how to access FILTER MENU

- Show FILTER and explain what it does
- Show CLEAN and FILTER (clean oil sensor on gas units)
- Show DISPOSE and explain what it does
- Show DRAIN TO PAN and explain what it does
- Show BOIL OUT and explain what it does
- Show PAN TO WASTE and explain what it does
- Show FILL VAT FROM PAN and explain what it does
- Show FILL VAT FROM BULK and explain what it does

STORE MANAGERS ONLY (OR DESIGNATED PERSONS)

Refer to Refer to the FilterQuick™ Quick Start Guide and the FilterQuick™ Controller Manual Chapter 1

- Demonstrate how to access MAIN MENU PROGRAMMING – (Press and hold CHECK) Code 1650
 - Demonstrate Product Setup and setting up an item and Assigning Buttons
 - Demonstrate how to add a new Menu Item – setup a test menu item (short cook cycle)
 - Demonstrate placement and use of the menu strip
- Demonstrate how to access INFO MODE (Press and hold INFO for three seconds)

Automatic Filtering Fryers



- Show FILTER STATS menu
- Show REVIEW USAGE menu
- Show LAST LOAD menu

Key Points

Review with all employees

- Start a cook on the fry station by pressing the cook button
- Clean and Filter daily
- Change filter pad daily or twice daily in high volume or 24-hour stores
- Filter Now? – Choose YES to Filter Now?
- Top Off Oil Empty – Change JIB and press reset (Bulk users fill JIB)
- Is Vat Full? – Answer YES only when oil is at the top line. Otherwise answer NO until oil is at the top line to prevent uneven oil levels

Training Date _____

Technician Signature _____ Printed Name _____

Manager Signature _____ Printed Name _____

Other Staff Signature _____ Printed Name _____

FAS: Provide a copy of all four (4) pages to the customer and to Frymaster. Retain a copy for two years from date of installation

Chapter 2: Oil Conserving Fryer



The Oil Conserving Fryer (OCF) is similar to the automatic filtering fryers. Like the LOV, and FilterQuick, it is based on the electric RE and gas H55 fryers, which are covered elsewhere. This unit, like the LOV, will require some special attention during installation. It must be leveled to ensure proper top off operation. The JIB must be installed and the top off system tested. See the embedded video below on installation. Other how-to videos are embedded where relevant.



OCF Electric Service
and Parts Manual



OCF Gas Service
and Parts Manual

OCF Fryers



The Oil Conserving Fryer, or OCF.

Points that separate the OCF, gas or electric, from the more traditional RE electric and H55 gas fryers:

- **Low Volume Frypot (LOV)** — 30 pounds rather than 50 pounds of oil.
- **Automatic Top Off (ATO)** — the fryer automatically maintains an optimal oil level from a reservoir in the cabinet.
- **3000 controller** — a sophisticated controller with multiple levels of programming.
- **Prompted filtration** — the controller keeps track of cook cycles and prompts for filtration, a manual function, when the cook count reaches a prescribed count, a user-programmable number.
- **Oil savings** — The combination of a low-volume fry vat and oil automatically kept at an optimal level reduces oil usage.

OCF Fryers

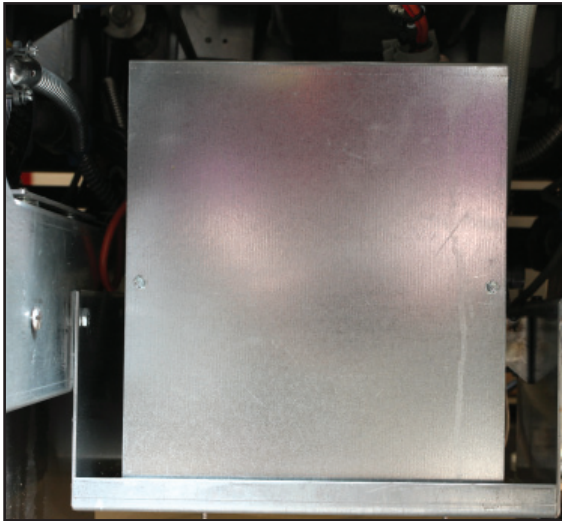

The ATO box is shown (above) with the JIB removed and (at right) with the cover removed.

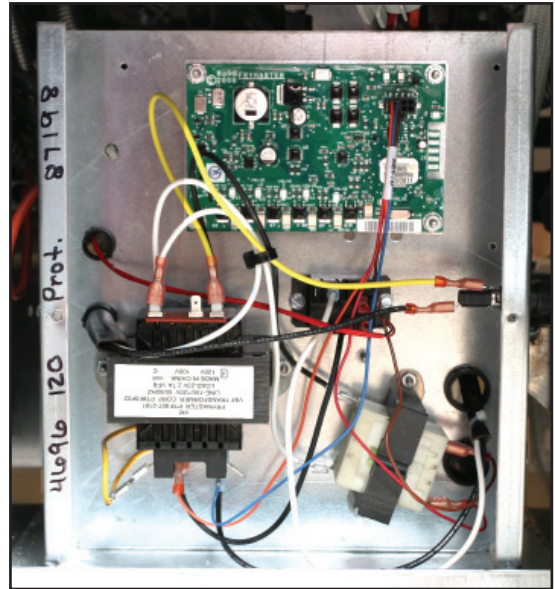

Auto Top Off

The core of the system is the automatic top-off board, which senses when the oil level is low and fills the pot to the top line.

The oil level is monitored by an RTD (Resistance Temperature Detector) sensor in the frypot at the upper oil level. The oil is moved from a reservoir, called a JIB (Jug In Box), to the frypot with a pump.

A circuit board, the ATO (Automatic Top Off), is located inside a box behind the JIB. It monitors the oil-level RTD and activates the pump when it senses an oil temperature drop of 60°F below setpoint, indicating the oil has moved away from the sensor. The ATO sends a signal to open the solenoid on the frypot to be topped off.

Once the solenoid has opened, oil is pumped into the vat for approximately 60 seconds. When the ATO RTD detects a temperature within 55°F of setpoint, it is satisfied and the solenoid closes. Top off will continue on the next vat if needed.

The activation of the system is handled by the fryer's controller, the 3000, and it is inactive until the frypot reaches setpoint, which is monitored by the temperature probe. The top off system is also inactive during filter/dispose cycles. The system is not suited to filling an empty frypot.

The level of the reservoir, or JIB, is monitored by the ATO and the 3000 controller. If two successive attempts (six minutes of pumping) to top off a fry pot fail, the 3000 scrolls *TOPOFF OIL EMPTY/CONFIRM*. It will stay illuminated until the JIB is replaced and the orange button has been pressed and held to reset the system.

The topoff system works the same in gas and electric OCF systems.



JIB Replacement video (Click on image)

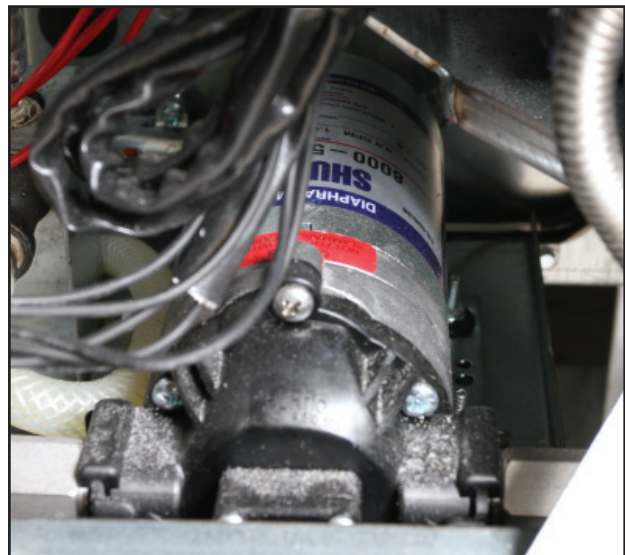

Top-off pump shown in place behind the ATO box.

OCF Fryers

ATO Board, front view

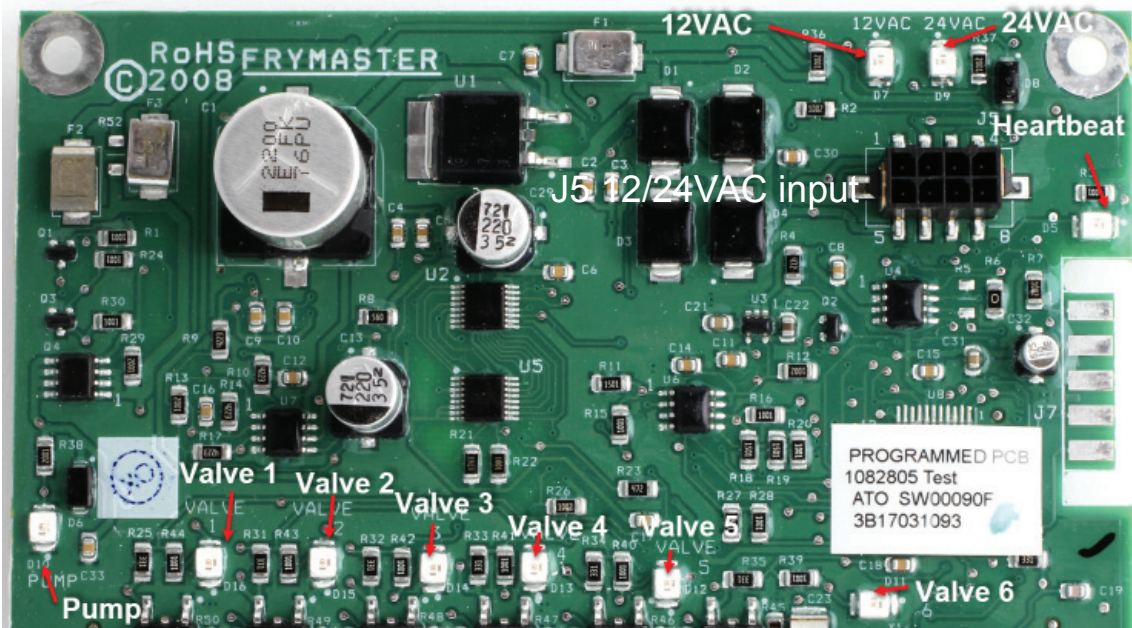

ATO Troubleshooting

When troubleshooting the automatic top-off system on an OCF fryer, put first things first:

- Check all controllers for software versions. Ensure all have the same version and all see the ATO software.
- Make sure there is oil in the JIB and the orange JIB reset button was pressed after the last JIB replacement.
- Ensure the fryer was power cycled with the hidden reset button.
- Go to Section 1.11 in the OCF electric or section 1.13 in the OCF gas service manual.
- Refer to provided guides for plug/harness locations and LED lights.
- Check the placement of the ATO probe in the frypot. It should be flush with the front of the frypot. If it is too deep in the recess, the frypot tops off too much.
- The fryer with the ATO box must be plugged into the wall for the ATO to operate.
- The fryer must be idle and at temperature — not cooking — for top off to occur.

Reading the ATO Board LED's

- LED 5 Heartbeat blinking
- LED 7 12VAC supplied to ATO board
- LED 9 24VAC supplied to ATO board
- LED 10 ATO board trying to turn on pump
- LED 16 Vat 1L solenoid voltage
- LED 15 Vat 1R solenoid voltage
- LED 14 Vat 2L solenoid voltage
- LED 13 Vat 2R solenoid voltage
- LED 12 Vat 3L solenoid voltage
- LED 11 Vat 3R solenoid voltage

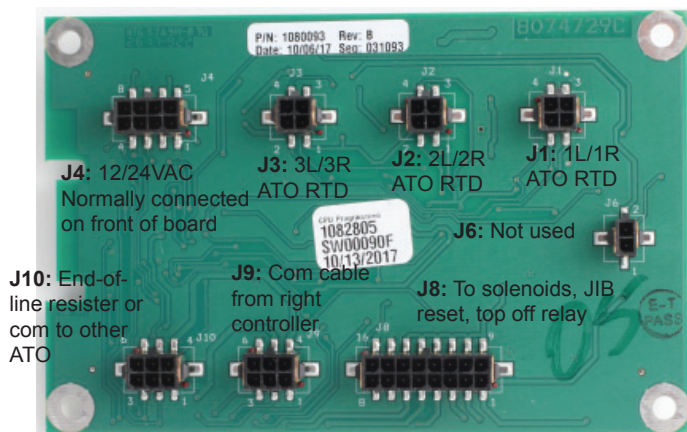

ATO Board, rear view

OCF Fryers

- The ATO system can be tested by pulling the JIB hose out of the oil in the JIB. Shift oil from a frypot to an adjacent frypot to take oil off the ATO probe. Bubbles should rise in the affected vat in two minutes or so as the pump tries to move oil into the vat. Check all vats in this manner. Allow the pump to run for six minutes in the last vat. Ensure the oil is low enough to prevent splashing onto the ATO probe. The controller display should say Top Off Empty - Confirm. The bubbling will stop. Return the hose to the JIB and press the orange JIB reset button several seconds to rearm the ATO system. The vat should begin topping off after the reset button is released.
- With the ATO box cover removed, jumper between the ATO relay common and normally open. This switches on the ATO pump when the 24VAC transformer has power to the common terminal. With the Pump LED 10 lit, the relay should be energized and the pump running.

LED's on Second ATO (If Present)

- LED 5 Heartbeat blinking
- LED 7 12VAC supplied to ATO board
- LED 9 24VAC supplied to ATO board
- LED 10 ATO board trying to turn on pump
- LED 16 Vat 1L solenoid voltage
- LED 15 Vat 1R solenoid voltage
- LED 14 Vat 2L solenoid voltage
- LED 13 Vat 2R solenoid voltage

Testing Top Off Components

- ATO pump measures 475 to 550 K ohms when new.
- Top off solenoids measure 4.5-5 ohms on the coil when new.
- Don't discard a part that is just off the mark.

OCF Top Off Plumbing

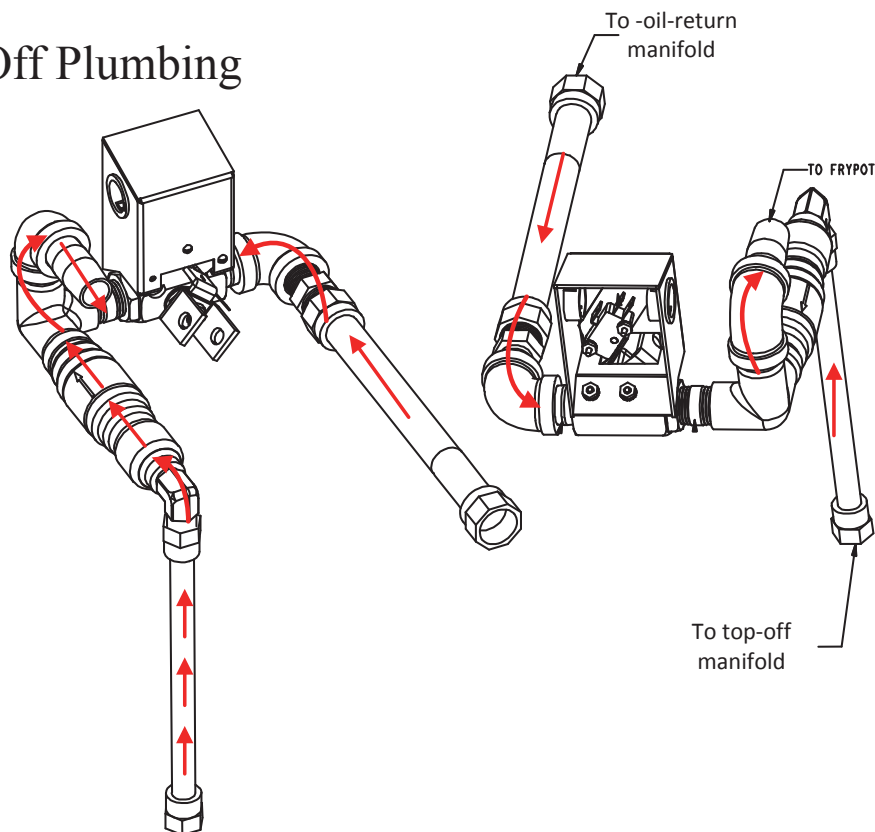

Oil flow in OCF's oil-return manifold

OCF Fryers

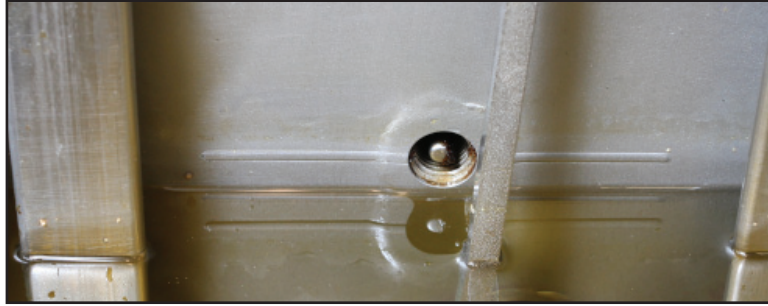

The oil-level RTD is shown (above) in the electric OCF and (at right) in the gas fryer, where it is in the front wall of the frypot.

Troubleshooting the Top Off System

Problem	Probable Causes	Action
<p>Frypots won't top off.</p>	<ul style="list-style-type: none"> A. JIB out of oil. B. Supply line from JIB is clogged. C. Probe temperature lower than setpoint. D. Temperature in supply line or JIB is too low. E. ATO board power loss F. Failed solenoid. G. ATO pump failed or over tightened. H. Failed transformer/harness. I. Failed ATO board. J. Top-off manifold solenoid failed closed. 	<ul style="list-style-type: none"> A. Ensure the JIB is not out of oil and supply line is in the JIB. Replace JIB and press the ▲ button when prompted to reset top off system. B. Remove supply line from pump and blow air through line toward JIB. C. Check to see that fryer is heating. Fryer temperature must be at least 300°F. Check probe resistance. If probe is bad, replace the probe. D. Ensure oil is above 70°F. E. Power to the ATO board has been cut off. Restore power to the board and switch all controllers off and on again to readdress system. F. Check solenoid to see if functioning properly. G. If the solenoid is working, ensure that the screws on the bottom of the pump are not too tight. Loosen the screws. If loosening the screws doesn't fix the problem, replace the pump. H. Ensure transformer in ATO box is functioning properly. Check power from transformer to ATO board. Ensure all harnesses are plugged securely into place. I. Check for proper voltages using the pin position chart. If ATO found defective, replace ATO board. J. A pressure switch opens in the pump with excessive pressure in the top-off manifold, shutting down the pump. Clear or replace solenoid.

OCF Fryers

Problem	Probable Causes	Corrective Action
Controller displays TOPOFF OIL EMPTY / CONFIRM	Top off system out of oil.	Fill top off system with oil and press the ▲ (CONFIRM) button.
Frypot tops off cold.	Incorrect setpoint.	Ensure setpoint is correct.
No power to ATO board	A. J5 connection unplugged. B. Fuse blown. C. Transformer malfunction.	A. Check to ensure J5 on front of ATO board is fully locked into connector. B. Ensure fuse below right control box is not blown and fuse on the right side of ATO box is not blown. C. Check that proper voltage is present at transformer.
One vat doesn't top off.	A. Filter error exists. B. Pump, loose connection, RTD or ATO issue.	A. Clear filter error properly. B. Check ATO pump, wire connections, RTD and ATO board.
One vat tops off but other vats fail to top off.	A. Failed solenoid. B. Loose wire connection.	A. Check power to the pump. If the pump is hot, the solenoid has probably failed. B. Ensure all wiring harnesses are securely connected to ATO board and solenoids.
Incorrect vat tops off.	A. Wired incorrectly. B. Flexlines connected to wrong vat.	A. Ensure wires are wired correctly. B. Switch flexlines to correct vat.
3000 displays SERVICE REQUIRED – ATO BOARD	A. Loose or bad fuse. B. Bad Connection. C. ATO Board power loss.	A. Ensure fuse on right side of ATO box is secure and good. If the controller above the ATO box is missing power, check the fuse below the component box. B. With the controller OFF, press TEMP button and ensure the ATO software version appears. If not, the connection between the ATO and the controller may be bad. Ensure the 6-pin CAN connectors are tight between controller (J6 and J7) and ATO (J9 or J10) boards. C. Power to the ATO board has been cut off. Ensure there is correct voltage to the ATO transformer. Restore power to the board and clear any service required errors.

OCF Fryers

Accessing the Controller



Screws across the bottom of the bezel hold the controllers in place. Support the bezel as the last screw is removed to ensure the framework doesn't drop. With the bezel removed, the removable menu strip on the 3000 controller is accessible (bottom left). Remove the screws on the upper corner of each controller and lower the units (bottom right) to view the CAN wiring and the content of the controller box.

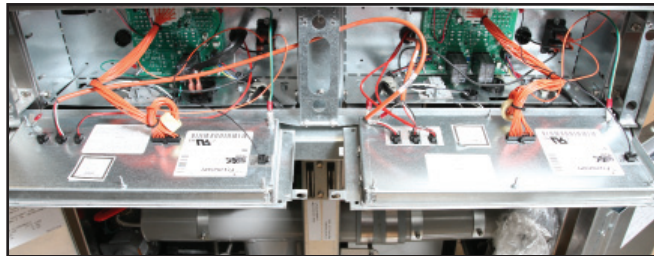
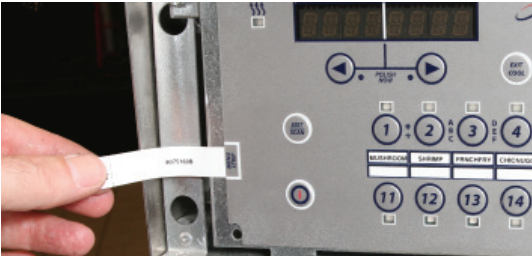

Control Power Reset Switch

The control power reset switch resets all power to the controllers and boards in the fryer. It is necessary to reset all power after replacing any controller or board. Press and hold the switch for at least 15 seconds when resetting the control power to ensure power has sufficiently drained from boards.

OCF Fryers

ATO (Automatic Top-Off) Board Pin Positions and Harnesses

Connector	From/To	Harness #	Pin #	Function	Voltage	Wire Color
J8	Solenoids	8075161 8075162- (4 or 5 battery)	1	Output DV - Vat #1	Ground	Green
			2	Output FV - Vat #1		Red
			3	Output DV - Vat #2		Green
			4	Output FV - Vat #2		Red
			5	Output DV - Vat #3		Green
			6	Output FV - Vat #3		Red
	Top Off Pump Relay		7	Top Off Pump	24VAC	Red
	JIB Reset Switch		8	JIB Reset	16VDC	Red
	Solenoids	8075161 8075162- (4 or 5 battery)	9	24VAC DV - Vat #1	24VAC	White
			10	24VAC FV - Vat #1		Black
			11	24VAC DV - Vat #2		White
			12	24VAC FV - Vat #2		Black
			13	24VAC DV - Vat #3		White
			14	24VAC FV - Vat #3		Black
	Top Off Pump Relay		15	Ground	24VAC	Black
	JIB Reset Switch		16	Ground	16VDC	Black
J4 (Rear) / J5 (Front)	Transformer	8074553	1	24VAC Ret	24VAC	Orange
			2	24VAC		Blue
			3			
			4			
			5	12VAC Ret	12VAC	Red
			6	12VAC		Brown
			7			
			8			
J3 - Vat 5&6 J2 - Vat 3&4 J1 - Vat 1&2	ATO RTD	1080501 (FV) 1080502 (DV)	1	DV - Probe Ground	Ohm	White
			2	DV - Probe		Red
			3	FV - Probe Ground		White
			4	FV - Probe		Red
J6			1			
			2			
J10	Network Resistor (pins 2 & 3) or to next ATO Board (4 & 5 vat units)	8074552	1	Ground		Black
			2	CAN Lo		Red
			3	CAN Hi		White
			4	5VDC+	5VDC	Black
			5	24VDC	24VDC	Red
			6	Ground		White
J9	3000 J7	8074646	1	Ground		Black
			2	CAN Lo		Red
			3	CAN Hi		White
			4	5VDC+	5VDC	Black
			5	24VDC	24VDC	Red
			6	Ground		White

OCF Topoff Wiring

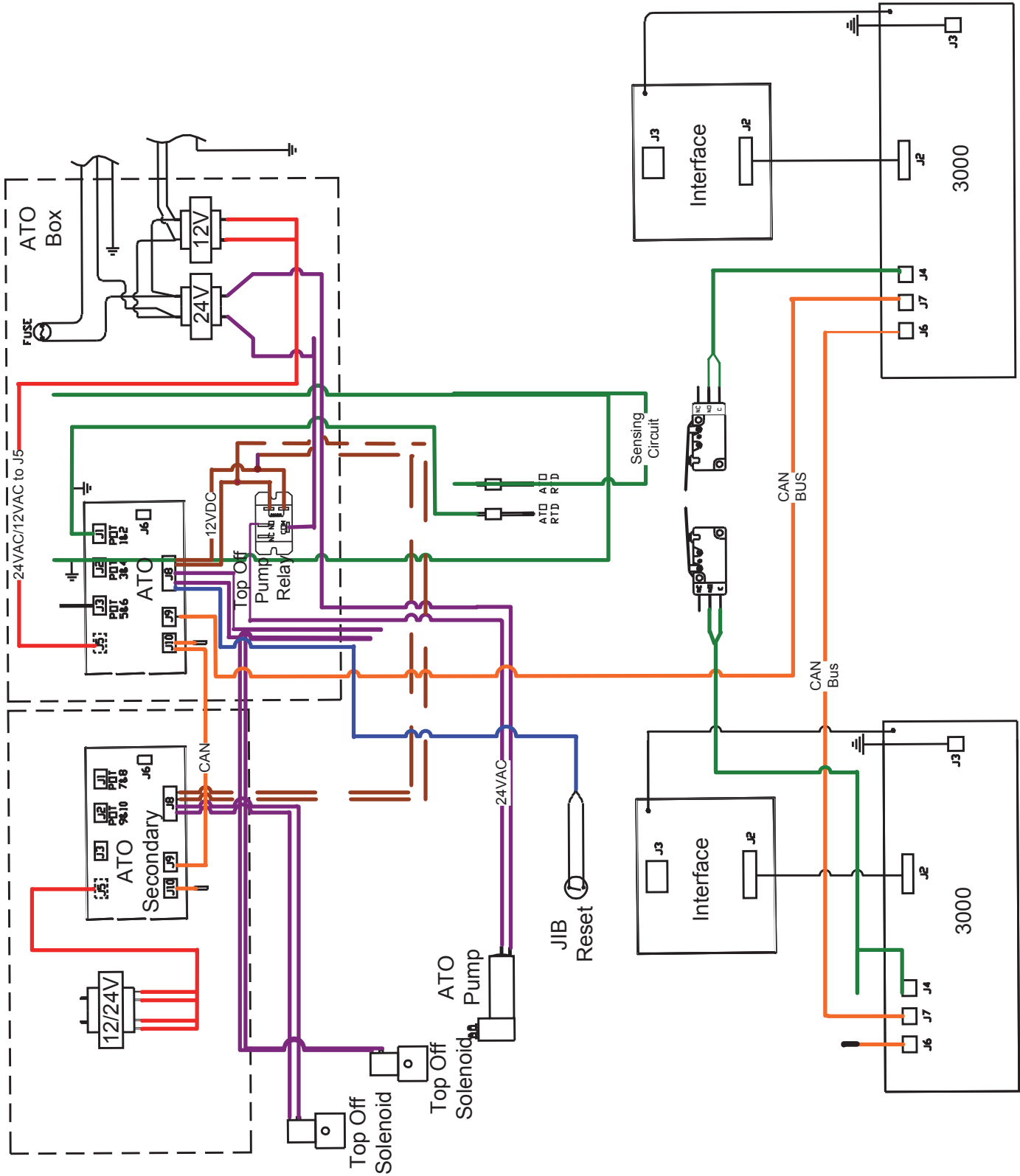

OCF Fryers

3000 Controller

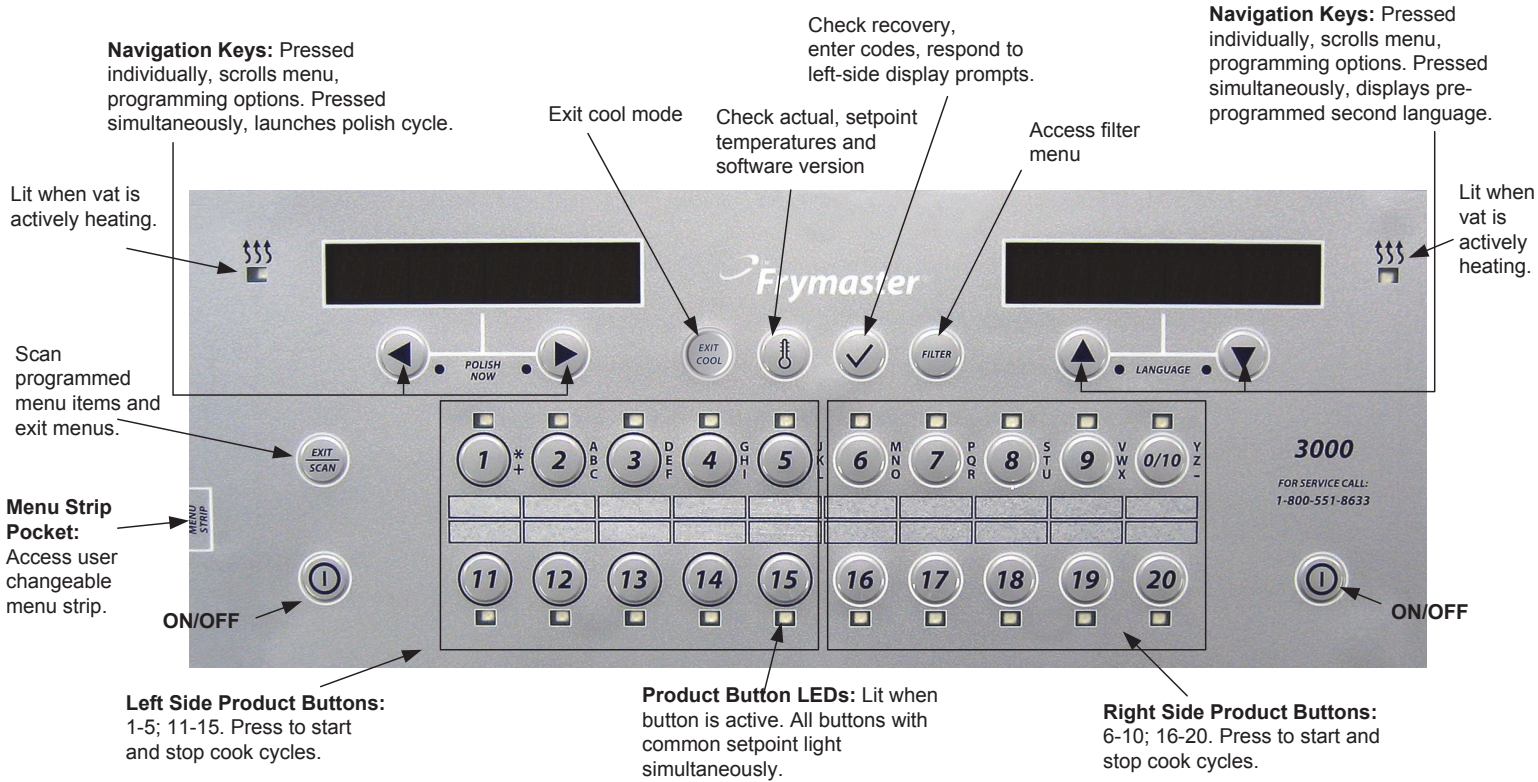

Button Explanation, Navigation

ON/OFF

- Press ON/OFF button fryer heats to setpoint or idle temperature and displays: COOL or DROP.

Cooking

- Fryer displays *COOL* or *DROP*
- COOL display: Press product button; fryer heats to setpoint and displays DROP.
- DROP display: Press product button and drop product.
- ** display: The vat temperature is out of the drop zone.
- DONE display: Press blinking product button to cancel alarm and end a cook.
- Cancel a Cook: Press and hold blinking product button to cancel cook cycle.
- HOLD display: Press blinking product button to cancel hold alarm.

Change setpoint: Press and hold a product button at the desired temperature until it beeps and a low tone is heard (approximately three seconds) and release.

Responding to Polish Prompt

- Controller displays Polish Now, alternating with Yes No.
- Press Yes (button under Yes display) and the polish cycle launches. Controller displays Cool after polish cycle.



The controller is also available in a 10-button version that is used by Hardee's and Carl's Jr..

OCF Fryers

Button Navigation

- **Product:** Press to start a cook cycle. Active when adjacent LED is lit. LED flashes during a cook cycle. Press and hold to cancel a cook cycle. Press at end of cook cycle to cancel an alarm. Press and hold a product with different setpoint (approximately three seconds) until it beeps to change setpoint temperature.
- **Scan/Exit:** Press once, all product buttons are lit; Select Product displayed. Press product button to view product name. Press Scan again to repeat. Press Scan twice to return to normal operation. Press scan to exit menus.
- **Left/Right Arrows:** Navigate options in left display. Press both simultaneously to start a polish cycle.
- **Up/Down Arrows:** Navigate options in right display. Press both simultaneously to change to a second language if one is selected in setup.
- **Exit Cool:** Exits cool mode, returns fryer to setpoint temperature.
- **Thermometer, Fryer ON:** Press and release for setpoint in left display and vat temperature in right display.
- **Thermometer, Fryer OFF:** Press to display temperature, time, date, system version, controller and circuit board software versions.
- **Thermometer, Fryer ON or OFF:** Press and hold three seconds to see ATO probe temperature.
- **Checkmark, Fryer OFF:** Press and hold 3 seconds: Scroll filter usage; Press and hold 10 seconds: Product setup.
- **Checkmark, Fryer ON:** Enter Codes, Respond to left display prompts.
- **Filter:** Press and release: Cooks remaining to filter cycle. Press and hold: Filter options: Filter, Clean and Filter, Dispose, Fill Vat from Bulk (Bulk option only) and Boil Out (OFF only).



Controller Overview Video (Click on image)



Vat Setup Video (Click on image)



Controller Ops Video (Click on image)



Single-Temp Programming (Click on image)

OCF Fryers

3000 Controller Menu Tree

Filter Menu

- [With computer ON, press and hold FILTER button]
- Filter
- Clean and Filter
- Dispose
- Fill Vat From Bulk (Bulk option only)
- Boil Out [With computer OFF, press and hold FILTER button]

Info Mode

- [Press and hold ✓(check) button]
- Last Dispose Stats
- Daily Stats
- Selected Period Stats
- Last Load Stats

Main Menu and Tech Modes

[With computer OFF, press and hold ✓(check) button 10 seconds, displays Main Menu - Product Setup]

- Product Setup
 - [Enter 1650]
 - Select Product
 - Long Name
 - Short Name
 - Cooking Mode
 - 1 Time
 - 1 Tempr
 - 1 Sensitivity
 - 1 Alarm Time (Shake)
 - 1 Alarm Name (Shake)
 - 1 Alarm Mode (Shake)
 - 1 Alarm Tone (Shake)
 - 2 Alarm Time (Shake) Time entered here, produces a 3rd alarm time.
 - Filter Prompt
 - Instant On
 - Hold Time
 - Load Standard (Load Default Product Menu)
- Vat Setup
 - [Enter 1656]
 - System
 - Language
 - 2nd Language
 - Locale (CE or Non-CE)
 - Energy (Gas or Elec)
 - Type (Vat)
 - System Volume (Sound Level)
 - Tempr Format (F or C)
 - Exit Melt Tempr
 - Cool Mode Tempr
 - Cool Mode Default
 - Fresh Oil
 - Waste
 - Drain Switch
 - Recovery Alarm
 - Basket Lift
 - Hold Time
 - Is Vat Full?
 - Time/Date
 - DST(Daylight Savings Time) Setup
 - Filter
 - Cooks til Filter
 - Filter Lockout
 - EOD Filter Timer
 - EOD Filter Time
 - Flushing Timer
 - Boil Out Timer
 - 1 Polish Timer
 - 1 Polish Prompt Time
 - 1 Polish Duration
 - 1 Polish Start Tempr
 - E-Log List of last 10 error codes
 - Change Password
- Tech Mode
 - [Enter 3000]
 - Clear E-Log
 - Clear Passwords
 - Lane Count
 - Hold Mode
 - Max Cook Tempr
 - Hi-Limit Test
 - Enable Filters
 - Enable Cooks

NOTE: Cooks and Filters are optional programmable features. In the controller's standard setup, Filters is turned on; Cooks is turned off. Steps associated with programming these features — which do not appear in the programming sequence if turned off — are shown in gray in this tree.

3000: Quick Reference

Pressed Individually: Scroll menu, programming options.
Pressed Simultaneously: Launches Polish.

Removable Menu Strip

Exit Menus, Scan programmed menu items.

Left Side Product Buttons: 1-5 and 11-15 are products for left side display.

Product Button LED: Lit when product is cooking or holding.

Right Side Product Buttons: 6-10 and 16-20 are products for right side display.

Access programming, respond to left-display prompts and check recovery.

Check actual, setpoint temperatures and software versions.

Access Filter Menu if enabled

Exits/Enters COOL MODE.

Product buttons. Press to begin and end a cook cycle. Press and hold to stop a cook.

Pressed Individually: Scroll menu, programming options.
Pressed Simultaneously: Changes to 2nd language if programmed.

- ON/OFF**
- Press ON/OFF button.** Fryer enters melt cycle before switching to full temperature and heating to setpoint.
 - Exit melt cycle by pressing and releasing the Exit Cool button or any programmed product button.** Displays show Exit Melt? on left and YES NO on the right. Press **▲** to exit.
- Cooking**
- COOL displayed:** Press product button or Exit Cool button; fryer heats to setpoint and displays READY. Press product button and drop product.
 - displayed:** The vat temperature is out of the READY zone.
 - READY displayed:** Press product button and drop product.
 - SHAKE displayed:** If shake is needed, alarm sounds.
 - DONE displayed:** Press product button to cancel alarm.
- Controller Button Navigation**
- Product:** Press to start cook cycle. Press at end of cook cycle to stop alarm.
 - Exit/Scan:** Press once, all programmed product buttons are lit; Select Product displayed. Press product button to view product name. Press right arrow to view parameters. Press Exit/Scan again to repeat. Press Exit/Scan twice to escape.
 - Left/Right Arrows (◀▶):** Navigate options in left display. Press and hold simultaneously to launch Polish cycle.
 - Up/Down Arrows (▼▲):** Navigate options in right display. Press and hold simultaneously to change language if programmed.
- HOLD displayed:** Press blinking product button to cancel hold alarm.
- Cancel Cook Cycle:** Press and hold product button.
- Thermometer (⏸): Fryer OFF:** Press and hold release to display temperature, time, date, system version, 3000 version. Press and hold for ATO board versions.
- Checkmark(✓): Fryer OFF:** Press and hold 3 seconds: Scroll filter usage; Press and hold 10 seconds: Main Menu-Product setup
- Checkmark(✓): Fryer ON:** Press and release: Check recovery. Press and hold 4 seconds: Info Mode.
- *Filter: Press and hold:** Filter options: *FILTER, CLEAN AND FILTER, DISPOSE, and BOWL OUT* (only with controller off).
- *Filter: Press and release:** *COOKS REMAINING.*
- (*NOTE: Functions only if enabled)

Filter Menu Navigation* (if Filters enabled)

Left Display	Right Display	Action
COOL READY	COOL READY	Press and hold Filter button for 10 seconds
*FILTER	Blank	Press ▶ to scroll to choices: Filter, Clean and Filter, Dispose, Fill Vat from Bulk (Bulk only) Boil Out (only with fryer OFF) and Exit. With the desired choice displayed press ✓ . *NOTE— Options only available if enabled.

* The Filter feature can be turned off. When Filter is disabled, the Filter button has no function. Pressing it with the fryer ON or OFF will have no effect. See page 1-2 of the manual for an explanation of enabling 3000 options.

Info Mode Navigation

Left Display	Right Display	Action
OFF or READY	OFF or READY	Press ✓ until INFO MODE is displayed and release.
LAST DISPOSE STATS	Blank	Press ▶ to scroll to choices: *LAST DISPOSE STATS, DAILY STATS, SELECTED PERIOD STATS, LAST LOAD STATS. With the desired choice displayed press ✓ . *NOTE: With Filter option disabled, not all data in these features will be collected.

Vat Setup Navigation

Left Display	Right Display	Action
OFF	OFF	Start with the far Left controller. Press ✓ until INFO MODE is displayed, changing to MAIN and then PRODUCT SETUP .
PRODUCT SETUP	Blank	Press ▶ to scroll to VAT SETUP .
VAT SETUP	ENTER CODE	Enter 1656
SYSTEM*	Blank	Press ▶ to scroll to choices: TIME/DATE , DST SETUP , E-LOG , CHANGE PASSWORD . With the desired choice displayed, press ✓ .

Common programming and navigation are shown below. The left and middle column show the computer displays; the right column has the action necessary to continue. Exit from a programming step at any time by pressing the Scan key until the display returns to its pre-programming status.

Programming For Single Setpoint Cooking*

Left Display	Right Display	Action
OFF	OFF	Press ✓ until Main Menu changing to Product Setup is displayed.
PRODUCT SETUP	Blank	Press ✓ .
PRODUCT SETUP	ENTER CODE	Enter 1650.
SELECT PRODUCT	Blank	Press desired product button.
LONG NAME	PRODUCT NAME OR BUTTON NUMBER	Enter product name with letter keys. Press ▶ .
SHORT NAME	PRODUCT NAME OR BUTTON NUMBER	Enter abbreviated product name with letter keys. Press ▶ .
1 TIME	0:00 or previously entered time	Enter time with numbered keys. Press ▶ . (Enter 0:00 here and press Exit/Scan to unassigned button.)
1 TEMPR*	TEMP	Enter new temperature. Press ▶ .
1 SENSITIVITY	NUMBER	Set to desired position with ▼▲ keys. Press ▶ .
1 ALARM TIME	0:00 or previously entered time	Enter time in cook cycle for audible alarm for shaking. Press ▶ .
1 ALARM NAME	SHAKE	Set to desired position with ▼▲ keys. Press ▶ .
1 ALARM MODE	AUTO OR MANUAL	Set to desired position with ▼▲ keys. Press ▶ .
1 ALARM TONE	SHORT	Set to desired position with ▼▲ keys. Press ▶ .
2 ALARM TIME	:00	This is a second alarm and is entered like the first.
FILTER PROMPT**	0	Enter the number of cook cycles for the product before a filter cycle is prompted.
HOLD TIME	0	Enter time in minutes to hold product before discarding. Press ▶ .
EXIT	EXIT	Press Scan button to exit or the ✓ button for additional programming.
SELECT PRODUCT	Blank	More Programming? Press product button and follow instructions above Exit Programming? Press Scan Button.
PRODUCT SETUP	Blank	Press Scan
OFF	OFF	

* The 3000 also has a segmented cooking program. The feature, called Cooks Mode, is used for bone-in chicken if desired and it is set to OFF by default. See the manual for enabling and programming this feature.

**Filter prompts occur in the programming sequence if the Filter Mode is enabled. This feature, which can be turned off, is set to ON by default. See the manual for instructions on disabling this feature.

OCF Fryers

3000 Controller Troubleshooting

Problem	Probably Cause	Action
No Display on Controller	<p>A. Controller not turned on. B. No power to the fryer. C. Power switch turned off. D. Loose fuse holder. E. Controller has failed. F. Damaged controller wiring harness. G. Power supply component or interface board has failed.</p>	<p>A. Press the ON/OFF switch to turn the controller on. B. Verify controller power cord is plugged in and that circuit breaker is not tripped. C. Some fryers have a rocker power switch inside the cabinet below the controller. Ensure the switch is turned on. D. Ensure fuse holder is screwed in properly. E. Swap the controller with a controller known to be good. If controller functions, replace the controller. F. Swap with a harness known to be good. If controller functions, replace the harness. G. If any component in the power supply system (including the transformer and interface board) fails, power will not be supplied to the controller and it will not function.</p>
3000 display shows filter busy	<p>A. Another filtration cycle is still in process</p>	<p>A. Wait until the previous filtration cycle ends to start another filtration cycle. This may take up to one minute. If filter busy is still displayed with no activity, remove and restore ALL power to the fryer.</p>
3000 display shows RECOVERY FAULT	<p>Recovery time exceeded maximum time limit for two or more cycles.</p>	<p>Silence the alarm by pressing the ▲ button. Check that fryer is heating properly. Maximum recovery for an electric: 1:40; gas: 2:25</p>
3000 display is in wrong temperature scale (Fahrenheit or Celsius).	<p>Incorrect display option programmed.</p>	<p>Incorrect display option programmed. The 3000 controller can toggle between F° to C° by pressing the ✓ button until Main Menu changing to Product setup is displayed. Press ► to scroll to Tech Mode and press ✓. Enter 1658. Press the scan button. The controller displays OFF. Turn the controller on to check temperature. If the desired scale is not displayed, repeat.</p>

OCF Fryers

Problem	Probably Cause	Action
3000 displays <i>SERVICE REQUIRED</i> followed by the error	An error has occurred.	Press YES to silence alarm. The error is displayed three times. Fix issue. The controller displays SYSTEM ERROR FIXED? YES/NO. Press YES. Pressing NO will allow the fryer to cook but the error will be re-displayed every 15 minutes.
Controller displays <i>CHANGE FILTER PAPER?</i>	Daily filter paper change prompt has occurred.	Press ▲ (YES), follow prompts and change the filter paper.
3000 display shows <i>HOT-HI-1</i>	Frypot temperature is more than 410°F or, in CE countries, 395°F.	This is an indication of a malfunction in the temperature control circuitry, including a failure of the high-limit thermostat.
3000 display shows <i>HI-LIMIT</i> .	Controller in high-limit test mode.	This is displayed only during a test of the high-limit circuit and indicates that the high-limit has opened properly.
3000 display shows temperature alternating with <i>MELT-CYCLE</i>	Frypot temperature is below 180°F.	Normal when the fryer is first turned on while in the melt cycle mode. To bypass the melt cycle press the EXIT COOL button for three seconds. <i>EXIT MELT</i> alternating with <i>YES/NO</i> is displayed. Press the YES button.
3000 display shows TEMP PROBE FAILURE	Problem with the temperature measuring circuitry including the probe.	This indicates a problem within the temperature probe circuitry. Check resistance of probe, if faulty replace probe.
3000 display shows PROBE FAILURE with alarm sounding.	Damaged controller wiring harness or connector.	Swap the controller wiring harness with one known to be good. If problem is corrected replace harness.
Controller will not go into program mode or some buttons do not actuate.	Failed controller.	Replace controller
3000 display shows HI 2 BAD.	Failed controller, failed interface board or open high limit thermostat.	Check high limit thermostat, interface board and controller.
3000 display shows HEATING FAILURE and alarm sounds, but fryer operates normally (false alarm).	Failed controller.	Replace controller.
3000 display shows CLOSE DRAIN VALVE	Drain valve is open or switch is out of adjustment or failed.	Ensure all drain valves are completely closed and that micro-switches are adjusted and working.
3000 display shows software for only 3000 or ATO board.	Loose or damaged harness	Replace card with another card.
3000 display shows CALL TECH	Shown during software update. Parameter data may be corrupt or lost.	Press the FILTER button to bypass and continue.

OCF Fryers

3000 Controller Useful Codes

To enter any of the following codes: Press and hold the ✓ button until Main Menu, changing to Product setup is displayed. Press ► to scroll to Tech Mode and press ✓. *TECH MODE ENTER CODE* is displayed. Enter a code number below:

7628 — Change Fryer Type, CE/Non-CE, Fresh Oil Setup, Waste Oil Setup, Energy Type and Reset Products.

3000 — Clear E-Log, Clear Passwords, Change Lane Count, Adjust Max Cook Temp and Perform High Limit Test.

3322 — Reset Factory Menu: The controller display flashes and quickly counts from 1-40 and switches to off. (NOTE: This will delete any hand-entered menu items).

9988 — Reset BADCRC Message - Disconnect board locator plug (J3). Reinsert plug. Controller display switches to off. Remove and then restore power to the controller using the 20-pin plug.

1658 — Change from F° to C° . The controller displays off. Turn the controller on and check temperature to see the temperature scale. If the desired scale is not displayed, repeat.

0042 — Reset RECOVERY FAULT CALL SERVICE.

Passwords

Product Setup Mode: Press and hold the ✓ button until *MAIN MENU*, changing to *PRODUCT SETUP* is displayed. Press the ✓ button. *ENTER CODE* is displayed. **Enter 1650.**

Vat Setup Mode: Press and hold the ✓ button. *MAIN MENU*, changing to *PRODUCT SETUP* is displayed. Press ► to scroll to *VAT SETUP* and press ✓. *ENTER CODE* is displayed. **Enter 1656.**

Tech Mode: Press and hold the ✓ button until *MAIN MENU*, changing to *PRODUCT SETUP* is displayed. Press ► to scroll to *TECH MODE* and press ✓. *TECH MODE* is displayed. Press the ✓ button. *ENTER CODE* is displayed. **Enter 3000** or a code from above.

OCF Fryers

Service Required Errors

A service required error alternating with YES displays on the controller. After YES is pressed, the alarm is silenced. The controller displays an error message from the list below three times with the location of the error. Then the controller displays SYSTEM ERROR FIXED? YES/NO. Press YES if error is fixed. If NO is chosen, the system returns to cook mode for 15 minutes then re-displays error until issue is fixed.

Code	Error Message	Explanation
E03	<i>ERROR TEMP PROBE FAILURE</i>	TEMP Probe reading out of range.
E04	<i>HI 2 BAD</i>	High limit reading is out of range.
E05	<i>HOT HI 1</i>	High limit temperature is more than 410°F.
E06	<i>HEATING FAILURE</i>	A component has failed in the high-limit circuit such as controller, interface board, contactor or open-high limit.
E08	<i>ERROR ATO BOARD</i>	ATO board connection lost; ATO board failure.
E17	<i>ERROR ATO PROBE</i>	ATO RTD reading out of range.
E20	<i>INVALID CODE LOCATION</i>	SD card removed during update.
E21	<i>FILTER PAPER PROCEDURE ERROR (CHANGE FILTER PAPER)</i>	25-hour or customer-set timer has expired.
E22	<i>OIL IN PAN ERROR</i>	Oil may be present in the filter pan.
E25	<i>RECOVERY FAULT</i>	Recovery time exceeded maximum time limit. Recovery time should not exceed 1:40, electric; 2:25, gas.
E27	<i>LOW TEMP ALARM</i>	Oil temperature has dropped 30°F lower than setpoint in idle mode or 45°F in cook mode. (This message may appear if a product is dropped and the start cook button is not pressed immediately or if too large cook loads are dropped.)

Testing ATO RTD probes.

The controller has a handy way to compare the temperature of the ATO RTD to the vat temperature. This is useful diagnostic tool.

With the controller OFF, press and hold the TEMP button. The controller will display AIF and ----- followed by ATO and current temperature. Ignore the AIF display. Compare the resistance of the ATO probe against the controller reading. If the values differ greatly, a harness issue may exist. See Probe Resistance Charts on pages 4-8 and 4-9.

Software Update

Updating the software requires recording and reloading cooking parameters. It can take a while. Follow closely the instructions, provided in the update kit.

The software only needs to be loaded in the left controller and it will update all the controllers and boards in the system. Press the TEMP button to check current 3000/ATO software version. Remove the bezel by removing the screws under the bottom of the bezel. Remove the two screws securing the controller, allow it to swing down. Remove the two screws on the left side cover plate.

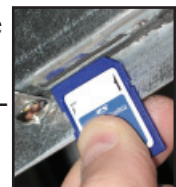

OCF Fryers

3000 Controller/Harness Pin Positions

Connector	From/To	Harness PN	Pin #	Function	Voltage	Wire Color
J2	Interface Board to Controller	8074199 SMT Controller to Interface Board Harness	1	12VAC In	12VAC	Black
			2	Ground		
			3	12VAC In	12VAC	
			4	FV Heat Demand		
			5	V Relay	12VDC	
			6	DV Heat Demand		
			7	R/H B/L	12VDC	
			8	Analog Ground		
			9	L/H B/L	12VDC	
			10	ALARM		
			11	Sound Device	5VDC	
			12	ALARM		
			13	FV Probe		
			14	Common Probes		
			15	DV Probe		
			16			
			17			
			18			
			19	Blower Cool Down Ground		
			20			
J3	Locator Harness Interface Board Ground to Controller	1080485	1	Vat #1		Black
		1080486	2	Vat #2		
		1080487	3	Vat #3		
		1080488	4	Vat #4		
		1080489	5	Vat #5		
			6			
J4	Drain Switch	8075159 (FV) 8075160 (DV)	1	FV Drain		Black
			2	FV Drain		Red
			3	DV Drain		Black
			4	DV Drain		Red
J6	Previous 3000 J7 or Network Resistor	8074546 Controller Communication Harness	1	Ground		Black
			2	CAN Lo		Red
			3	CAN Hi		White
			4			
			5			
			6			
J7	ATO J1 or Next 3000 J6	8074646 Controller Communication Harness	1	Ground		Black
			2	CAN Lo		Red
			3	CAN Hi		White
			4			
			5			
			6			

OCF Fryers

OCF Options: Bulk Oil

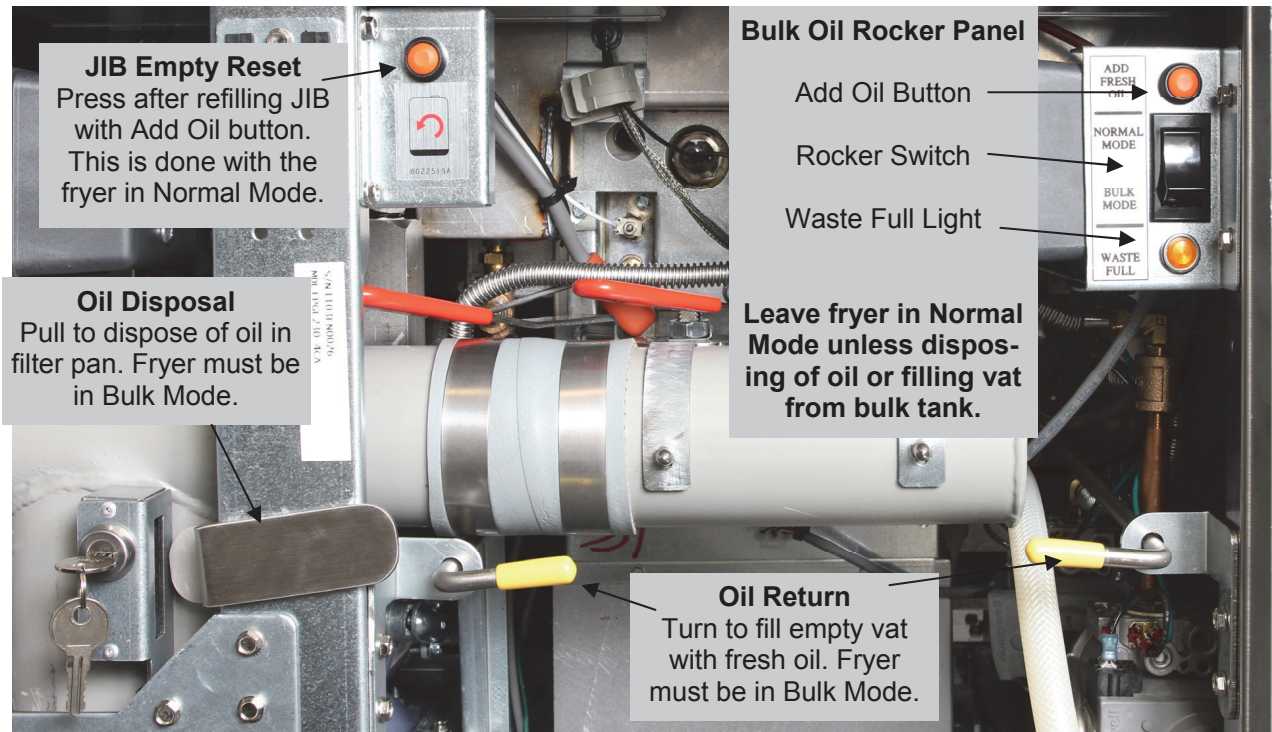

Bulk oil controls in the cabinet.

The OCF can be equipped with a bulk oil system. The fryer is connected to reservoirs for fresh and waste oil. The ATO system JIB, a plastic jug usually provided by the bulk oil provider, is filled with the controls shown above. Oil is pumped to the waste oil reservoir from the filter pan using the valves shown above.

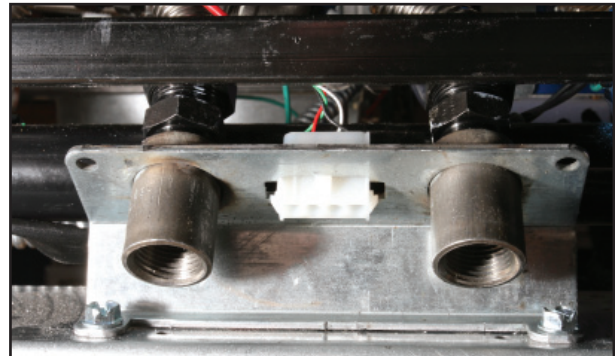

The connection ports for the bulk oil system are shown above. The wiring for the system is shown in the diagram at left below.

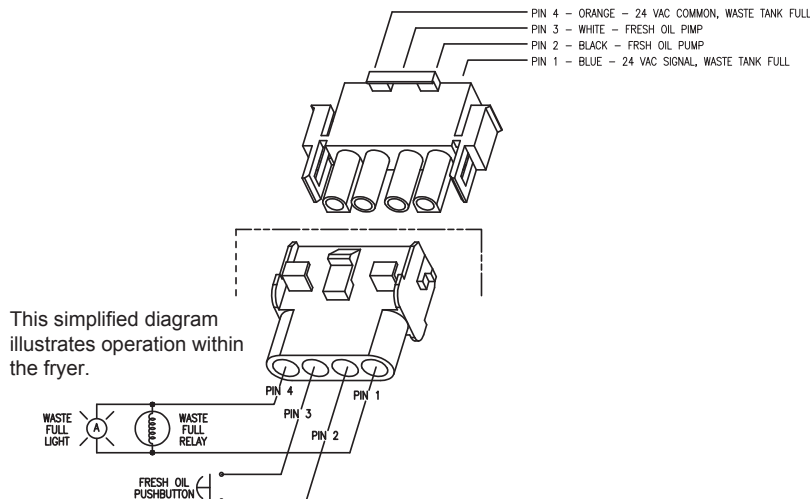

OCF Fryers

Bulk Oil Operation

— Switch on Filter Mode

• Filtration

- Control switch must be on Normal.
- Disposal valve must be closed.
- When oil return valve opens, filter pump is energized and power to the fresh oil push button is disconnected.

• Fill JIB from Bulk

- Control switch must be on Normal.
- Check valve protects oil flow into waste system or filter pump if dispose valve is left open.
- When fresh oil button is pressed, there is a 2-second delay prior to turning on fresh oil pump. This enables the fresh oil solenoid to open without pressure applied.

— Switch on Bulk Mode

• Dispose

- Control switch must be on Bulk.
- 24 VAC signal for Waste Full will disable pump.
- Dispose valve open disables power to oil-return switches.

• Fill Vat from Bulk

- Control switch must be on Bulk.
- Fresh oil solenoid is disabled.
- Filter pump is disabled when fresh oil button is pressed.
- Oil return valves are open but switches are disconnected to eliminate filter pump running dry.

Bulk Oil Wiring Diagram

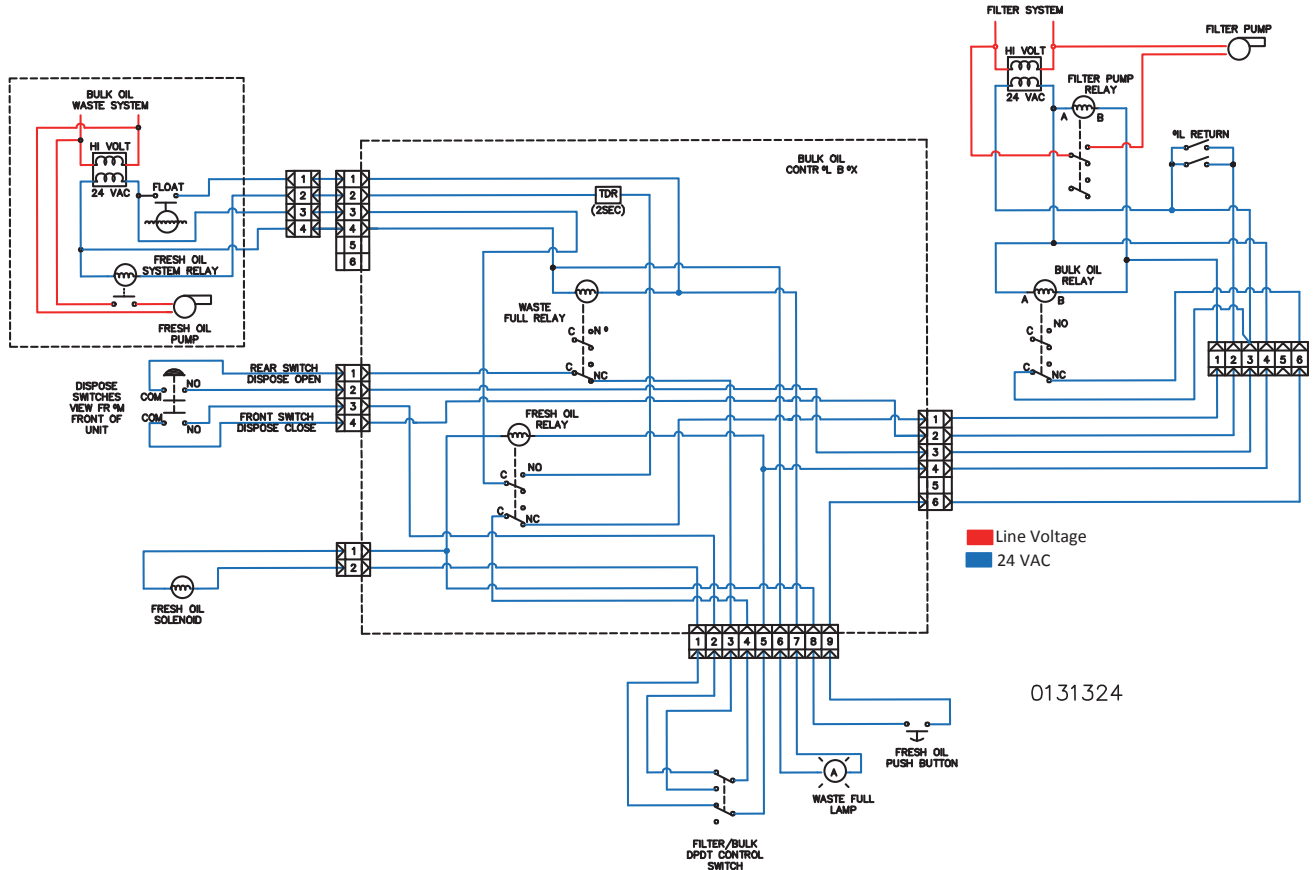

OCF Fryers



OCF 30 FRYER START-UP FORM

8700 LINE AVE, SHREVEPORT, LA 71106 (800) 551-8633

Date _____

Store Name _____
 Store # (if applicable) _____
 Address _____
 City/State _____
 Store Phone (____) _____

Technician _____
 Service Agency _____
 Address _____
 City/State _____
 Country _____

FRYER/FILTER MODEL NUMBER	SERIAL NUMBER (10 DIGIT)

- No one is to perform start-up or training unless they are Level 3 certified and their certification is current.**
- Verify fryers have 6" (15cm) of clearance provided to each side and behind fryer to combustible materials YES NO
- Remove Warranty Label date tabs
- Ensure fryer is level and properly restrained in accordance with the operator's manual.
- Operators should be thoroughly familiar with the operations manual and use of the fryer and controller before use.
- Perform VAT SETUP on all controllers. Refer to IO manual, Chapter 1. **Record Software Controller** _____ **ATO** _____
- Ensure Time and Date are correct in setup.**
- Review and demo programming features with manager. Refer to manual.
- Is the fry system being installed connected to a **BULK OIL SUPPLY / DISPOSAL SYSTEM** (RTI or similar)? YES NO
- If fryer was setup as a **BULK OIL SUPPLY / DISPOSAL SYSTEM** (RTI or similar) was power cycled after setup? YES NO
- Place full JIB in fryer for ATO system, or fill JIB provided from Bulk Oil Company (as applicable). Refer to manual.
- Thoroughly clean and dry all vats. Fill all vats with oil to 1/2" below cold oil line. Allow fryers to heat to set point (**see gas and electric checks below**) and verify temperatures are at set point +/- 5°F / 2°C. **Verify that oil level is below ATO level sensor (upper oil level line / add/remove oil if necessary) and ensure that each vat tops off from JIB.**
- Check restaurant to ensure that it doesn't have a severe positive or negative air balance.
- GAS** fryers - While units are heating up, check incoming gas pressure (Natural Gas: 6-14" W.C.; LP Gas: 11-14" W.C.). Record actual incoming pressure _____. Check burner manifold pressure. Record actual burner manifold pressure below. Check for proper combustion; fryers should have a bright orange flame after approximately 1 minute of operation. Adjust blower air inlet to achieve .3 – .9 uA (micro amps) on each igniter flame sense circuit. Record micro amp readings below.

Gas	Vat #1	Vat #2	Vat #3	Vat #4	Vat #5	Vat #6	Vat #7	Vat #8	Vat #9	Vat #10
Burner Pressure										
Left uA										
Right uA										

- ELECTRIC** fryers - While units are heating up, ensure applied voltage matches the rating plate. Ensure all phases are balanced and there is no current draw when controller heat light is off.

AMP DRAW										
Electric	Vat #1	Vat #2	Vat #3	Vat #4	Vat #5	Vat #6	Vat #7	Vat #8	Vat #9	Vat #10
L1										
L2										
L3										

- Verify that all filter parts (filter pan, filter screen, filter pad or paper, filter powder, hold-down ring, crumb tray, and O-rings) are present. Inspect the oil drain and return system to ensure all connections are tight.
- Verify filter pan alignment.
- Perform a filtration on all vat(s) to ensure the filter pump is operational and check the drain and return system for leaks.
- Review 3000 Controller Quick Reference Guide
- The startup tech is responsible for training the operators following the "Training Outline Form" PN 8196969.

(1.5) hours are allowed for the above to Start-Up one system.

Manager's Signature _____ Technician's Signature _____

FAS: Provide a copy to the customer and to Frymaster. Retain a copy for two years from date of installation

8196494
08/2016

OCF Fryers



OCF FRYER TRAINING OUTLINE FORM

One and one-half hours are allowed for the following training/demo for each bank of fryers.
No one is to perform start-up or training unless they are Level 3 certified and their certification is current.

Ensure all trainees refer to the Quick Reference, Quick Start and Operation Manual.
Hands-on demonstration is essential for all trainees.

CREW/FILTRATION PERSON(S) / MANAGERS

OVERVIEW

- Provide an overview of what an OCF is Vs traditional fryer – Smaller vat, Low Oil Volume.
- Explain the benefits when used properly – Use less oil, Auto Top Off.

COMPUTER

Identify 3000 Computer buttons and functions / LED's for OCF – Refer to the 3000 Quick Start Guide

- ON / OFF Buttons — Demonstrate full and split functions.
- Cook Cycle Buttons — Demonstrate a cook cycle/stop a cook cycle.
- Exit Cool Button — Demonstrate entering and exiting the energy-saving Cool Mode.
- Temp Button — Demonstrate Use: **ON** – Setpoint and vat temperature; **OFF** – Temp, time, date, software versions.
- Checkmark Button — Demonstrate Use: **ON** – Enter codes, respond to prompts; **OFF** – Press and hold 3 seconds: Scroll filter usage.
- Filter Button — Demonstrate Use: Press and release: Cooks remaining to filter prompt; Press and hold: Filter options.
- Exit Scan — Demonstrate Use: Scan programmed menu items and exit menus.
- Master Power Switch (per vat) (US ONLY).

Demonstrate JIB System (JIB and Bulk Oil Systems) – Refer to the OCF Quick Reference Guide

- Demonstrate setup of the JIB.
- Filling vats with oil (Bulk or JIB).

AUTO TOP-OFF (ATO) – Refer to the OCF Quick Reference Guide

- Instruct on function Top Off Oil Empty Display
- Demonstrate pressing JIB reset after JIB replacement.
- Demonstrate Auto Top-Off on a vat by moving oil out of vat

Prompted Filtration – Refer to the OCF Quick Reference Guide

- Demonstrate assembly of the filter pan (Emphasize need for daily pad change / more often as needed)
- Show “FILTER Now” displayed on vat to be filtered. Explain YES and No Response.
- Show location of thermal reset on Filter Motor

TROUBLESHOOTING

- Common error messages
 - Filter Busy – a filtration process is in another vat
 - Probe Failure – Temperature circuitry has a problem – Turn off fryer and call for service
 - Heating Failure – Unit is not heating – Turn off fryer and turn on again.
 - Low Temp – Oil temperature below set point – may occur during cooking cycle
 - Recovery Fault – Vat did not meet minimum specs for temperature recovery – Press the ✓ to continue.
 - Service Required – a problem exists that requires a technician.
- Frymaster's Hot line and ASA contact person / with phone numbers

OCF Fryers

FILTRATION PERSON(S) / MANAGERS

Refer to OCF Quick Reference Guide and Operations Manual

- FILTER MENU** (Press and hold LEFT or RIGHT FLTR button based on the type of vat being filtered)
 - NON BULK OIL SYSTEM**
 - Demonstrate how to access FILTER MENU
 - BULK OIL SYSTEM**
 - Demonstrate how to access FILTER MENU

STORE MANAGERS ONLY (OR DESIGNATED PERSONS)

Refer to OCF Quick Start Guide and Operations Manual Chapter 4

- Demonstrate how to access PROGRAMMING –**
 - Demonstrate Product Selection and Assigning Buttons
 - Demonstrate how to add a new Menu Item – setup a test menu item (short cook cycle)
 - Boil Out
 - Demonstrate placement and use of the menu strip
- Demonstrate how to access INFO MODE (Press and hold INFO for three seconds)**
 - Show FILTER STATS menu
 - Show REVIEW USAGE menu
 - Show LAST LOAD menu

Key Points

Review with all employees

- Start a cook on the fry station by pressing the cook button
- Maintenance filter daily
- Change filter pad daily or twice daily in high volume or 24 hour stores

Training Date _____

Technician Signature _____ Printed Name _____

Manager Signature _____ Printed Name _____

Other Staff Signature _____ Printed Name _____

Chapter 3: FilterQuick Touch



FilterQuick FQGLA-T used in Burger Kings

The FilterQuick Touch was introduced in summer and fall of 2017. The fryer is a variation of the LOV fryer and has many of the same features: 30-lb frypots for improved oil efficiency, automatic filtration, automatic top



— Continued on Page 3-3

Video Content

Features

- **Advanced touchscreen controller**
- **Wireless connectivity for off-site monitoring**
- **Automatic intermittent filtration**
- **Low-volume frypots**
- **Redesigned interface board**
- **Redesigned oil-return monitoring**

Acronyms

- **SIB** — Smart Interface Board
- **VIB** — Valve Interface Board
- **FIB** — Filter Interface Board (Like LOV's ATO and MIB)
- **ATO** — Automatic Top Off system
- **OQS** — Oil Quality Sensor
- **FQ4000** — Touchscreen controller
- **UI** — User Interface, another name for touchscreen
- **C-Bus** — Data connection between SIB's, FIB, SUI
- **P-Bus** — Data connection between SIB's and VIB's
- **MOD-Bus** — 24VDC and data from FIB to VIB's, SIB, UI
- **USB** — Universal Serial Bus used to upgrade software
- **SUI** — Communication between fryer and monitoring network

NOTE: The fryer's top off, oil quality sensor and rotary valve actuators are like those on the auto filtering fryers and are covered in that section.



FilterQuick FQGLA-T used in Taco Bell

Touchscreen-Equipped Fryers

Manuals, Online Support for FilterQuick

The FilterQuick fryer with a touchscreen controller was initially built on a chassis used on a Japanese-specific fryer. The current production, which began in December 2017, fryer is built on a different platform.

Due to the different platforms, there are two parts manuals. 819-7446 for the earlier fryer and 819-7478 for the later model.

The most pronounced visual difference between the fryers is the style of door handle. The earlier fryer has black recessed door handles. The newer model has curved stainless handles on the top of the door.



FQGLA-T (early)



FQG30-T (current)



[FilterQuick Training Module](#)

[Taco Bell-Specific Training Module](#)



FQGLA-T Installation/Operation



FQGLA-T Parts



FQGLA-T Service



FQ4000 Controller/
TB



FQ4000 Controller



FQG30-T Parts

Scan with smart-phone QR-code reader to access manuals. Click links to access posted training modules. Cover nearby QR-codes to ensure desired manual is retrieved.

Touchscreen-Equipped Fryers

— Continued From Page 3-1

off and, optionally, an oil quality sensor, which monitors the oil as it is used and displays on the screen when it is time to discard.

The fryer features a touchscreen controller, which assumes the diagnostic role of the Manual Interface Board used in the earlier LOV fryers, and introduces a new set of circuit boards and sensors to monitor the flow of the oil and the performance of the fryer:

- A Smart Interface Board (SIB)
- A Filter Interface Board (FIB)
- A Valve Interface Board (VIB)

Sensors in the frypot monitor the level of the oil for the top off system (ATO) and automatic filtering (AIF). In gas fryers there is an optional Oil is Back sensor (OIB), which prevents the burners from igniting without sufficient oil in the vat.

Vats without the OIB look at the temperature difference between the temperature probe and the AIF before allowing the burners to ignite.

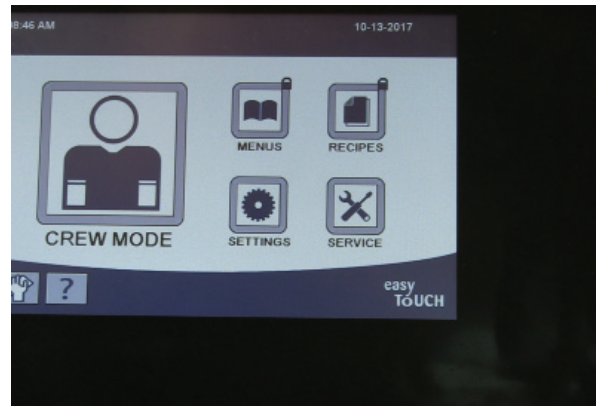

The touchscreen FQ4000 makes training the staff easier and it also introduces a number of diagnostic options. Valves can be opened, closed, blower motors run.

Chain-Specific Controller Screen Configurations



Burger King/General Market



Taco Bell

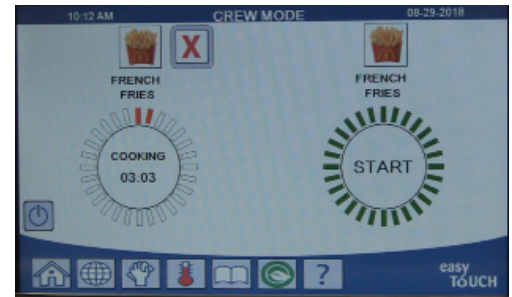

McDonald's

The touchscreen controller is configurable to meet a chain's needs. A general market (largely Burger King) screen is shown above. It has multiple buttons across the bottom, including a manual top-off button. The Taco Bell screen (right, above) has fewer buttons, but includes a oil quality reading (green box at bottom right) and the McDonald's screen (right, above) has fewer cooking icons, showing only french fries on this vat.



Video Content

Touchscreen-Equipped Fryers



Accesses Menus. Allows changing the displayed array of products, dinner items vs. lunch items for example.

Change displayed language.

Accesses Crew Mode

Total Polar Material (TPM) reading, a measure of the oil's quality.

Manual top off, allows top off pump to be run manually

Access fryer use and maintenance data also software version numbers

Accesses Cool Mode, a feature that reduces the holding temperature of an idle frypot

Accesses Menus. Allows changing the displayed array of products, dinner items vs. lunch items for example

Accesses Temperatures, actual and setpoint

Accesses Filter menus

Change displayed language

Accesses Crew Mode

Same Controller, Different Interface

The Taco Bell unit (shown in the OFF position, above, left) continuously displays vat temperature and the Total Polar Material count of the oil is shown in a small box at bottom right. The TPM display box changes from green to yellow to red as the oil's TPM numbers move toward discard.

The interface changes in cooking mode. Taco Bell (below and on previous page in cooking mode) adds a setpoint display and a filter button.

As chains experiment with the touchscreen, some are changing display, adding or subtracting buttons.

The Home screen (bottom right) is accessed by the Home key on any controller. That screen makes Menus, Recipes, Settings and Service areas available.

Menus is where time-of-day products are found, for example, breakfast. Recipes is where cooking parameters are changed and new products are added.

Service provides access to service items such as component check. Settings is where specifics such as oil type, day and time, language, etc. are set.

Pressing any produces a Service or Manager button or both. All require passwords. See section on using diagnostic features in the controller.



The Taco Bell controller adds a filter icon to its display when in cooking mode.

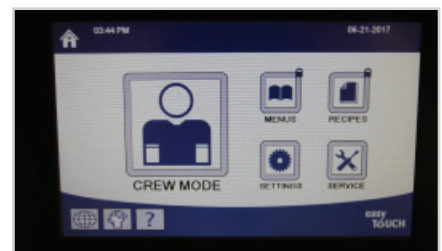

The Home screen accesses Crew Mode for cooking; Recipes to change cooking parameters; Menus to change available items; Settings to change vat/fryer settings; Service to access diagnostics.

Touchscreen-Equipped Fryers

Critical Circuit Boards and Their Locations

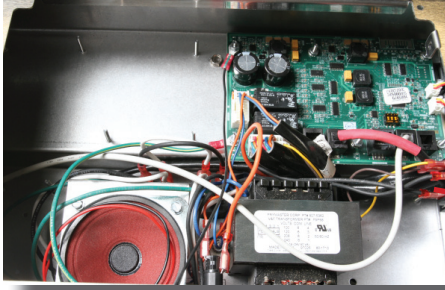

The Smart Interface Board (SIB) is located behind the touchscreen controller.



The Valve Interface Board (VIB) is located under each vat. Replacement boards come encased in sheet metal.

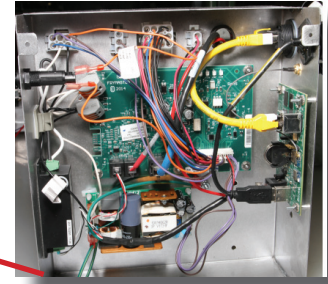

The Filter Interface Board (FIB) is in a box with other components behind the JIB. The box also contains the SUI communication board and power supplies for the top off pump and the communication components.

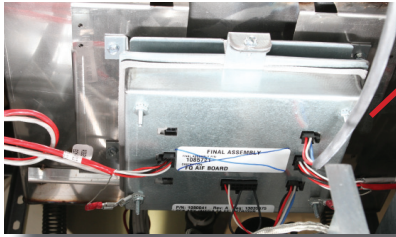

Calling for Top Off Oil Sequence

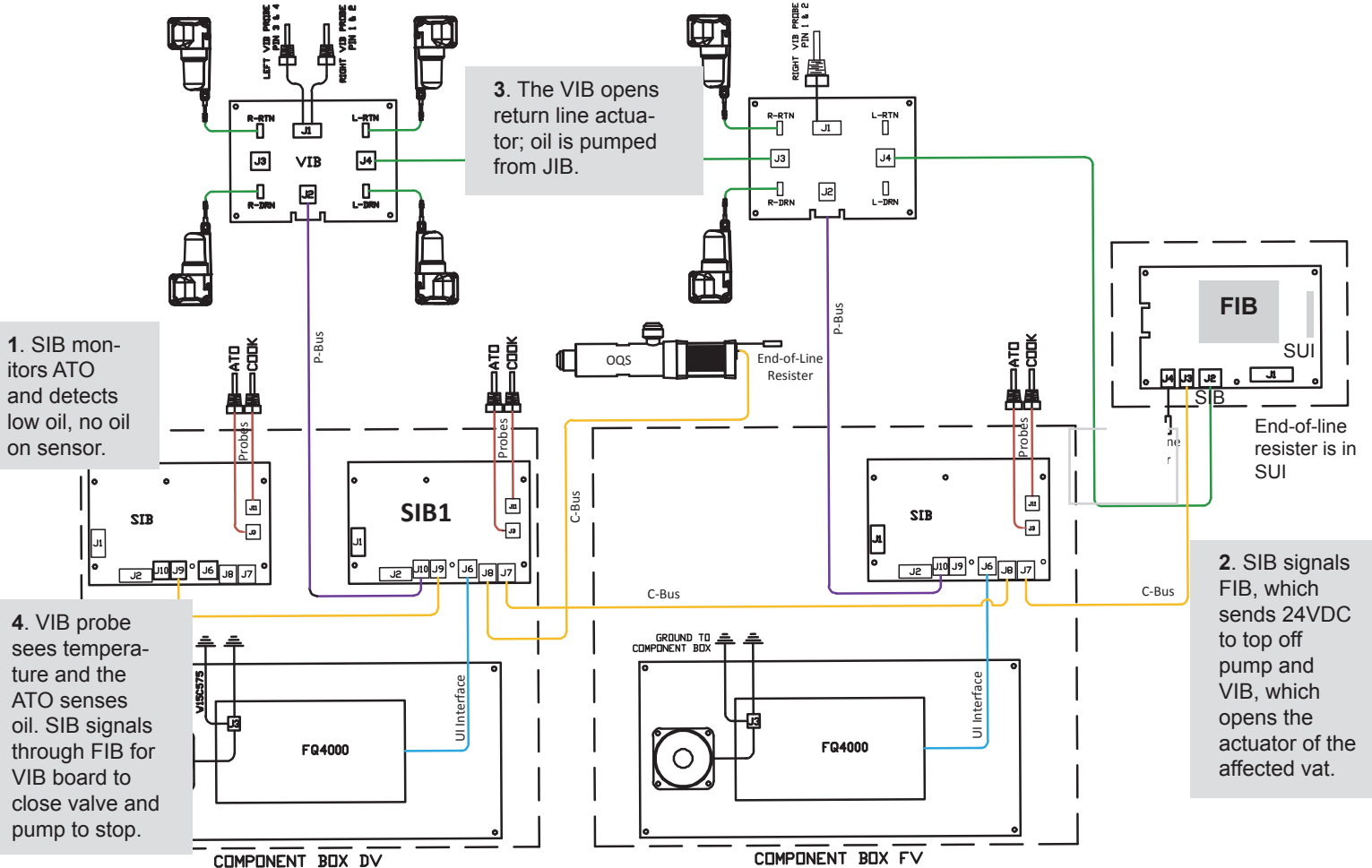

Touchscreen-Equipped Fryers

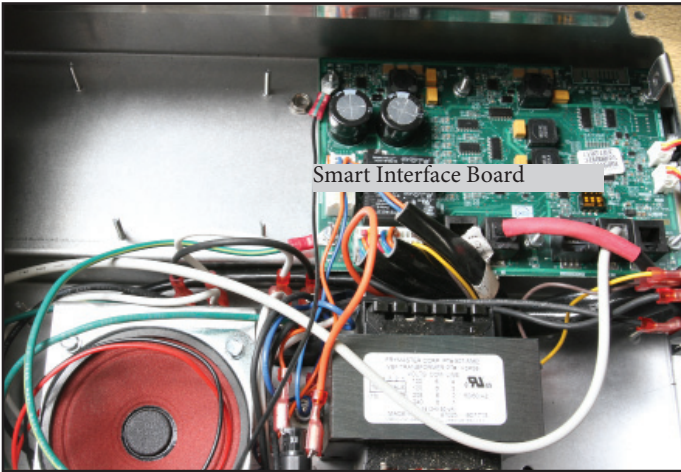

1: Smart Interface Board (SIB); one for each controller and in control box.

The circuit boards work in unison to monitor the oil temperature, keep the vats topped off and ensure the oil is filtered and oil is returned before the vats are heated. (See the circuit board pictures and the diagram in this section.)

The SIB monitors the Automatic Top Off Probe and passes signals to the Filter Interface Board when oil is off the probe. The Filter Interface Board sends 24VDC through the VIB board to the rotary actuator on the return valve of the affected vat and 24VDC to the top off pump.

Oil flows from the JIB until the Automatic Top Off probe senses the oil. The SIB then signals to halt the filling. The FIB closes the return valve and stops the top off pump. The VIB senses temperature and allows the vat to heat.

The automated filtration has a similar sequence. The SIB monitors cook cycles in some chain stores and calls for a filtration when the programmed cook count is reached for the product in question. In other stores, the SIB signals for a filter twice a day, AM and PM. The AM filter is longer and prompted cleaning steps are displayed.

After a Yes response to a displayed filter request, the SIB signals the FIB to open with the VIB board the drain on the affected vat. Oil drains to the filter pan. The SIB notes a drop in temperature in the vat. The SIB signals the FIB and it starts the filter pump.

The steps of the filter cycle and prompts for cleaning are displayed on the touchscreen. When the timed filter cycle is complete, the FIB signals the VIB to close the drain and open the return. Oil is

— Continued on Page Next Page

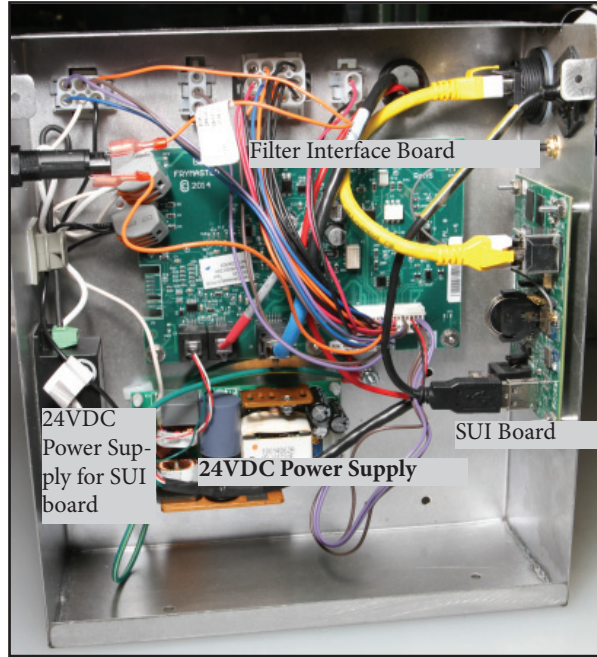

2: Filter Interface Board (FIB) in FIB Box behind JIB.

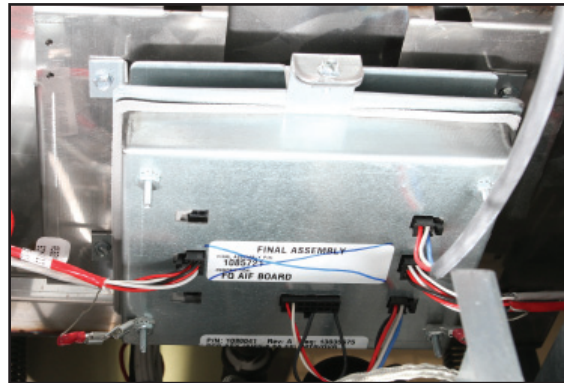

3: Valve Interface Board (VIB); one under each vat.

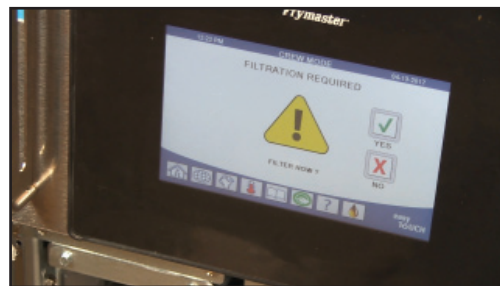

The FQ4000 used by Burger King calls for filtration after a programmed number of cook cycles is reached.

Touchscreen-Equipped Fryers

pumped back to the frypot.

The temperature and VIB probes look for the oil to leave the frypot and also for its return. The screen asks if the frypot is full when the cycle is complete. Pressing Yes causes the frypot to heat the oil to setpoint.

Operational issues in the store can cause filtering problems. (See below.)

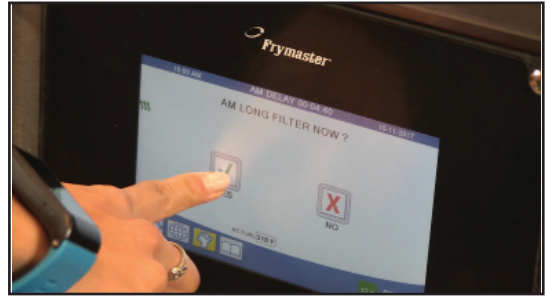

The FQ4000 configured for Taco Bell calls for filter cycles in the morning and evening. The morning filter is longer and includes cleaning.

Troubleshooting Recurring Operational Issues

Failure to properly clean the filter system or the OIB sensor can lead to heating failures in gas fryers.

Common store-introduced problems are:

- Oil not completely returned because of dirty filter pan or in-line filter.
- Fryer is turned off during a required filter.
- Required filters delayed beyond the allowed one-hour time limit.
- Adding oil to a vat with a display showing low oil rather than correcting the problem.

The frypots in gas fryers are monitored to ensure oil is in the pot after a filter cycle. Fryers with an optional oil is back (OIB) sensor deny voltage to the gas valve if the oil is not sensed. Gas fryers without the optional OIB, monitor the difference between the temperature probe and the AIF probe as the oil is returned after a filter.

Each approach is a safety to ensure there's enough oil in the vat to safely turn on the burners.

In fryers without an OIB, a difference greater than 19°F between the AIF and the temp probe is seen as an absence of oil in the frypot. The controller displays a low-oil message and the frypot shuts down. Pressing the Yes button on the screen launches a safe mode start up routine:

If the problem occurs as oil is returned after a filter cycle, the controller displays a series of messages and graphics on cleaning the filter pan or the in-line filter. The test sequence, after acknowledging the issue with the Yes button, is:

- The fryer doesn't call for heat for 2.5 minutes and then enters a four-minute window in which it calls for heat for 10 seconds and then is off for 24 seconds. The 2.5 minute downtime can appear to be an unrelated problem. It's just the fryer doing its job.
- If, during this melt-cycle like process, the temperature gap between the probes closes to less than 19°F, the frypot will resume normal heating.
- If the temperature gap is not resolved in the test period, the controller displays an E81 error and locks out. A passcode, 4-3-5-7, is required to start the fryer.



Failure to refill the frypot after a filter cycle causes heating failures. The problem is often related to cleaning the frypot, filter system.



Video Content
Low Oil Troubleshooting Video

Touchscreen-Equipped Fryers

The problem is usually a clogged or dirty filter pan or in-line filter, which prevent oil from returning to the vat quickly and completely.

Adding oil to the frypot to close the gap between the probes doesn't correct the problem.

The problem with the flow of oil from the filter pan must be resolved.

Different Issues, Similar Problem

A less frequent cause of the low oil display occurs when a vat — off for a while — is turned on again.

- The oil at the top of the vat cools faster during the off period than the oil low in the vat.
- The gap between the probes can be great enough when the fryer is restarted to cause the low oil display.
- Stirring the vat with a basket, redistributing the hotter oil, can rectify this problem.

Another in-store issue is failure to acknowledge and run a request for a required filter in a Taco Bell-specific fryer. The controller locks out and displays a filter message and 0:00, indicating the one-hour window allowed to run a requested filter has elapsed.

The filter can be started by pressing the filter message. The filter will run, the error cleared and the vat will resume regular operation.

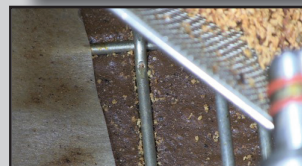
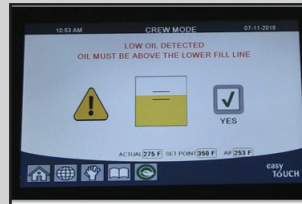
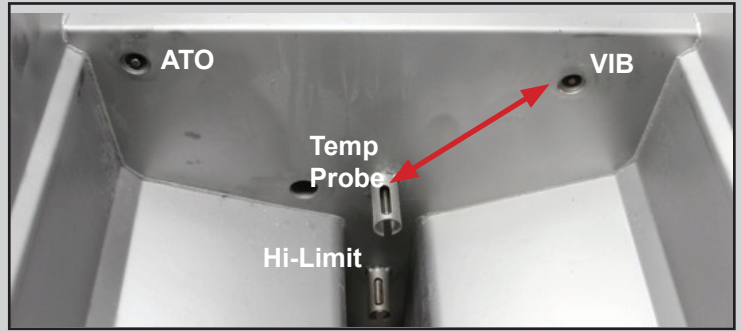

1. A 19°F difference between the measurements of the temp probe (bottom probe, above) and the VIB probe (top probe) causes a low-oil message. If unresolved, an E81 error is displayed.

2. The problem is usually caused by a dirty or clogged filter pan (left) or a clogged (below) in-line filter.

3. The problem is not readily resolved by just adding oil. That can add to the problem. Cold oil at the top doesn't close the temperature gap and the additional oil will overflow the filter pan, which is still holding oil.

OIB Requires Cleaning to Avoid Fryer Heating Problems

The oil-is-back sensor serves as a safety to prevent the gas fryer from heating before a vat is sufficiently filled.

The heat of the constantly powered oil sensor rises when the 350°F oil leaves the pot. (See graphics below.)

When the temperature of the probe reaches 550°F, the line voltage supplied through a time-delay board begins to switch on and off every four seconds.

The switching opens a coil that, when closed, provides 24VAC to the gas valve and a ground reference to the AIF board.

When the OIB sensor is running too hot, the vat's burner won't fire.

A sensor caramelized with oil is insulated from the "cooling" of the frypot oil, which can cause it to heat to its setpoint and open the coil.

The sensor (right) must be cleaned frequently.

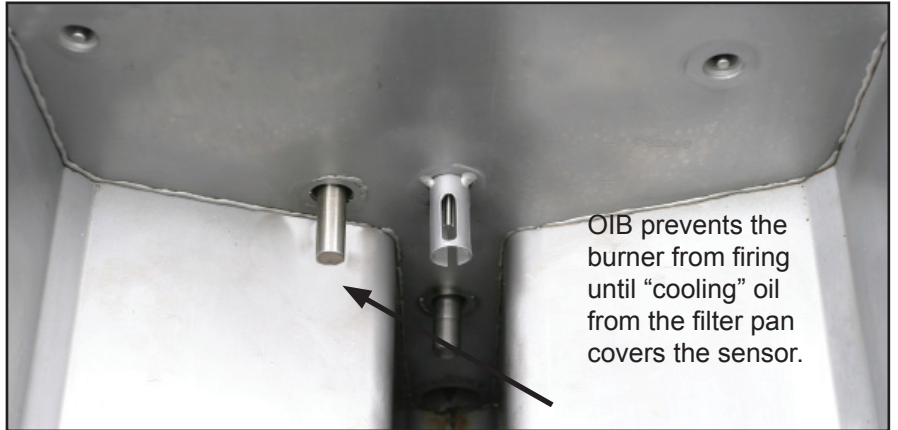

Cleaning the sensor daily or more frequently is required to prevent heating issues.

- 1 The OIB sensor, a heated probe, rises in temperature to over 550°F when oil is out of the frypot.
- 2 At its setpoint, it begins 4-second power cycles to control its temperature.
- 3 The 4-second cycling disrupts the 7-second relay in series with the OIB sensor. The 7-second relay opens, denying 24VAC to the gas valve and ground reference to the VIB.
- 4 Return of oil cools the probe and the 4-second cycling ends. After 4 seconds, the time relay closes and power and ground are restored.

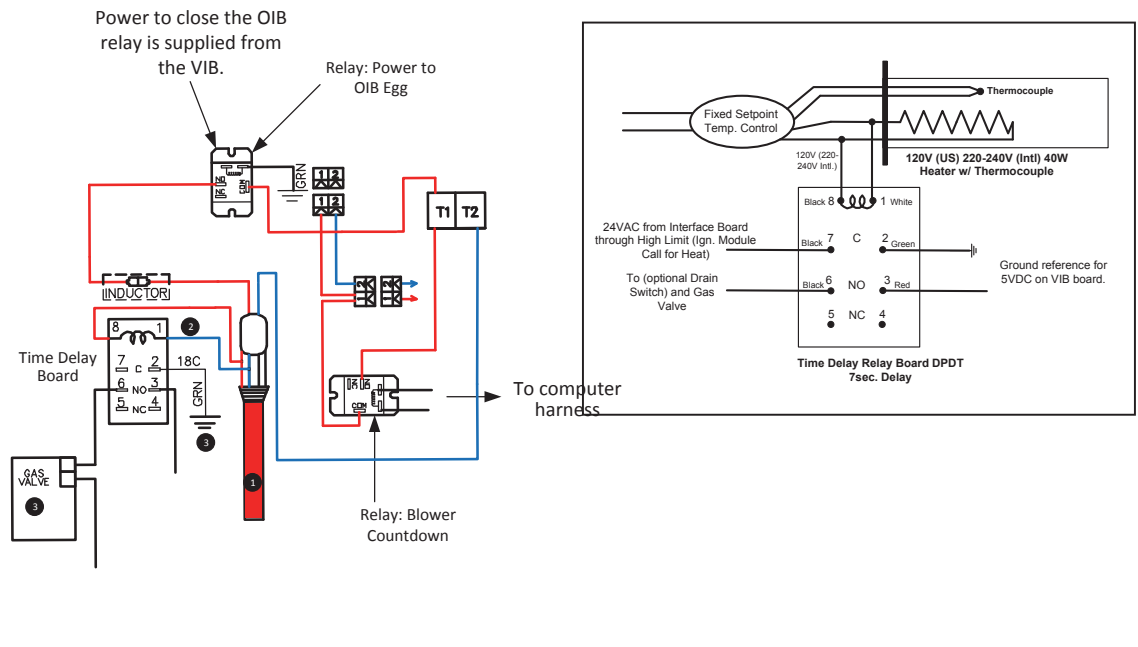

Touchscreen-Equipped Fryers

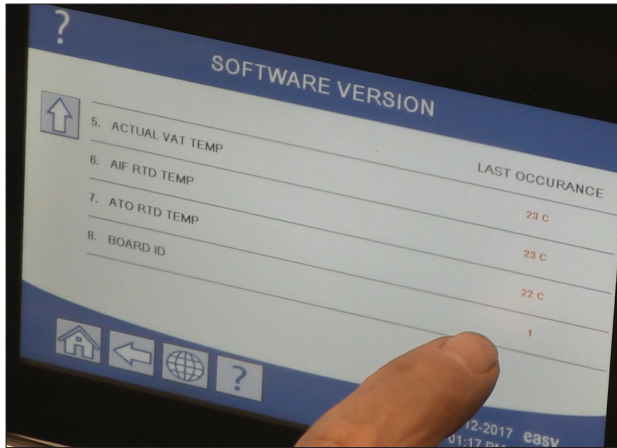

Missing software versions on the display is indicative of network problems. Wide variation in ATO and temperature probe readings suggests oil level or probe issues.

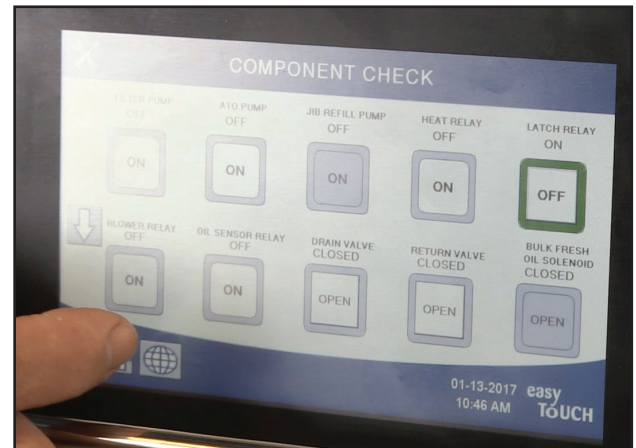

Components, such as relays and valves, can be tested with the Component Check feature.

Use Controller's Version, Component Check Features for Diagnostics

Two features in the controller make checking on the presence and performance of components in the network easy. Navigating to the Software version window allows temperature comparison between the ATO probe and the vat temperature displayed by the temperature probe. A dramatic difference indicates a probe problem or an oil level problem.

Navigating to the Component Check window, allows relays to be opened/closed, latch relays to be checked, blower motors to be run.

Use Software Display for Diagnostics

- Press the Home button
- Press the Question Mark button.
- Press the down arrow to navigate to the Software version icon.
- Press the software icon.
- Press the down arrow to scroll the software versions for each component: SIB, FIB, VIB, SUI, etc.
- The numbers should match current version numbers.
- The absence of numbers or the presence of all zeros in a component field means that component is not being seen on the network.
- Scroll with the down arrow again to the temperature display for the ATO and the temperature probe.
- The numbers should be very close. A big difference indicates a probe issue or an oil level problem.

How to Use Component Check Feature

- Turn the fryer off.
- Press the Home button
- At the Crew Mode screen, press the Service icon
- Press the Service Man Icon.
- Enter 9-0-0-0 on the keyboard.
- Press the check mark.
- Tap Tech Mode.
- Navigate to the Component Check screen and press the button.
- The controller populates with buttons for fryer components.
- Turn the components on and off as necessary to check component function. Listen closely for relays to open and close.
- Be careful opening drain valves and running pumps.

Touchscreen-Equipped Fryers

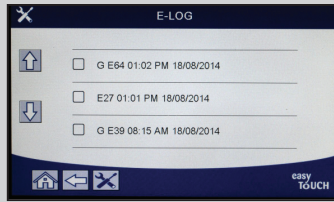

Use Error Codes to Track Problems

- Press Home button.
- Press Service button.
- Press Manager button.
- Enter 1656
- Press check mark.
- Scroll recorded error codes with up and down arrow keys.
- The codes are displayed, in the order they were recorded, in fields of three.
- The guide to the over 40 error codes can be found in the controller manual. There's also a video guide to responding to error codes.
- Error codes can point to operational issue, such as failure to filter, that lead to required maintenance.

Draining to Pan/Filling From Pan

When a repair, such as a probe replacement, requires draining a vat, the controller is used to move the oil to the filter pan. Follow the steps below to drain the affected frypot.

- Press the Filter button.
- Select vat (if split) to drain from display.
- Scroll to Drain to Pan and select it.
- Press check mark.
- Ensure the filter pan is fully inserted.
- Press Blue button to start draining.
- Insert Pan is displayed if pan is not fully in place.
- Draining is followed by Vat Empty.
- Tap Yes when the vat is empty.
- Follow prompts to return oil to vat when work is finished.

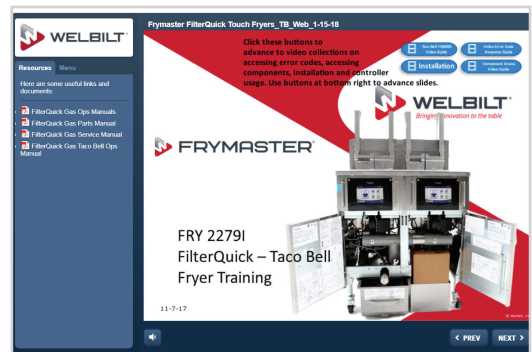

Video Content FilterQuick Touch Training Module

Touchscreen-Equipped Fryers

Reading the LED's on the Fryer's Circuit Boards

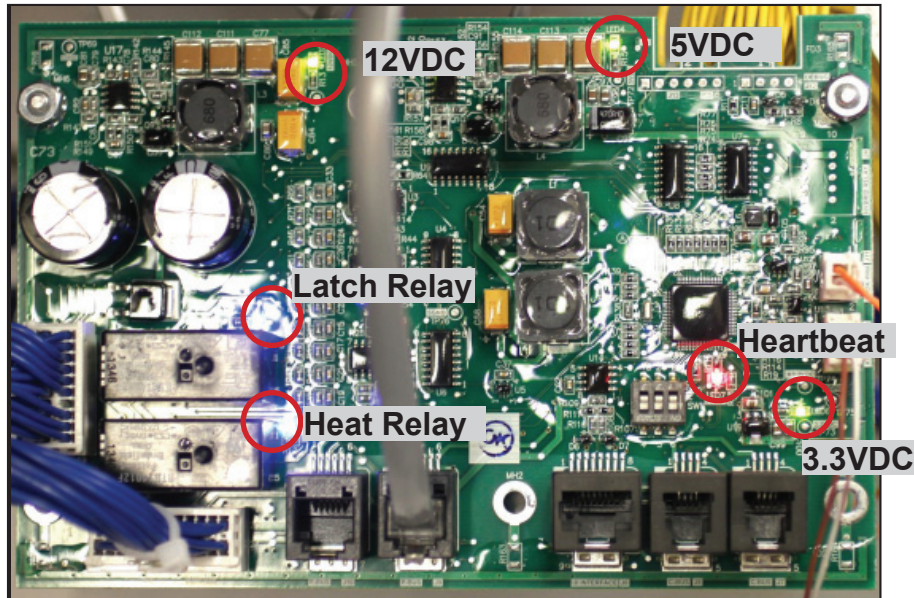

Smart Interface Board with LED's illuminated.

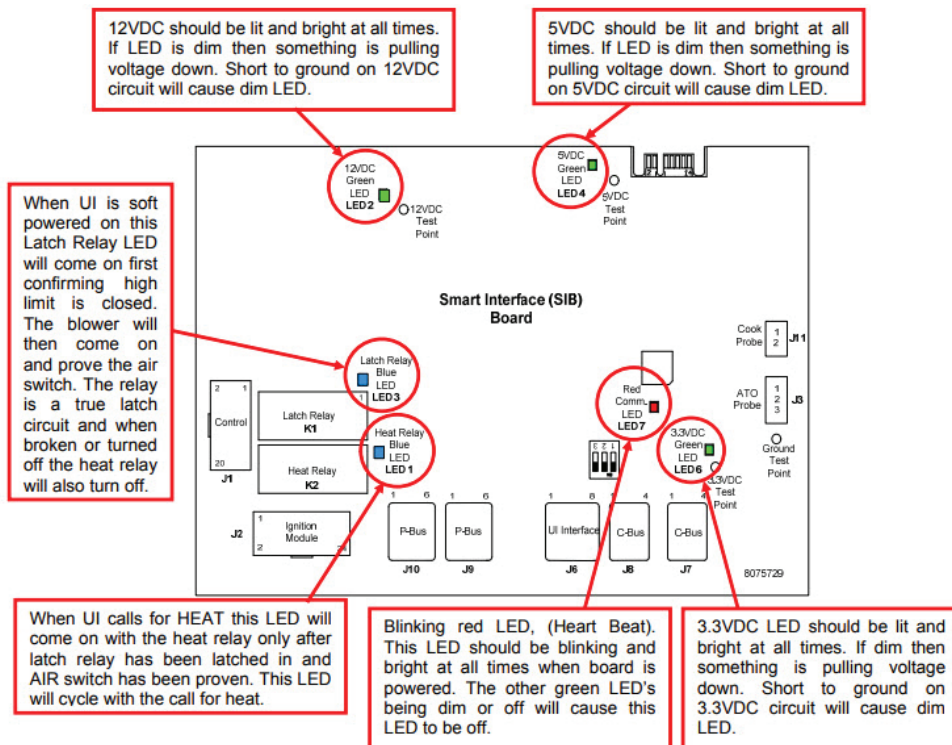

Touchscreen-Equipped Fryers

The Smart Interface Board, in the control box, and the Filter Interface Board, in the box behind the JIB, have LED's that help with diagnosing electrical problems.

The SIB gets 24VAC and converts it to 12, 5 and 3.3 VDC. The controller runs on 12VDC and uses 5VDC to monitor the probes. The processor in the SIB runs on 3.3 VDC.

The closing of the latch and heat relays can be monitored on the SIB.

The FIB's LEDs show current flow to the relays and pumps for the filter and fresh oil replacement pumps.

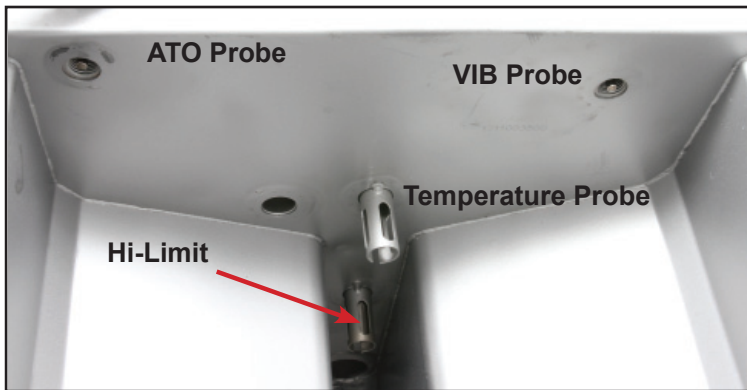
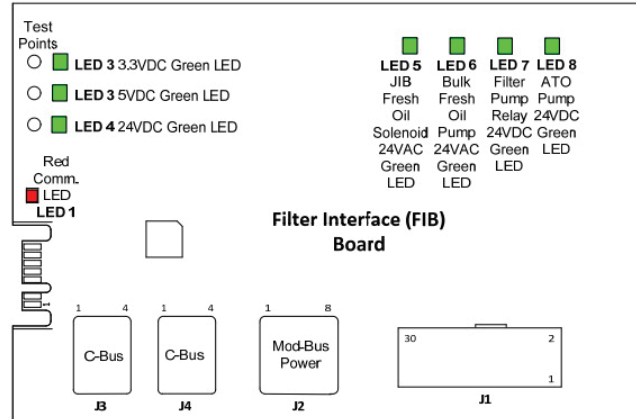

The controller and the SIB, in fryers without an OIB sensor, rely on the temp and AIF probes in the frypot (left) to monitor cook temperature, and oil movement.

The FQ4000 configured relies on sensors in the fry pot to track the level of the oil during filter cycles and calls for top off.

Component Access, Identification

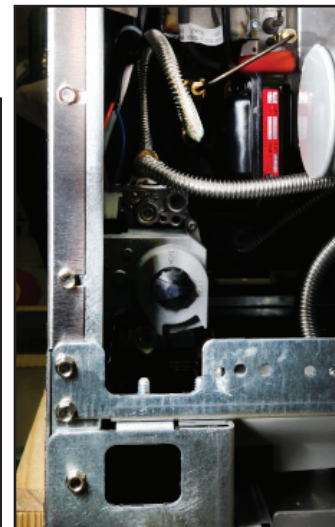
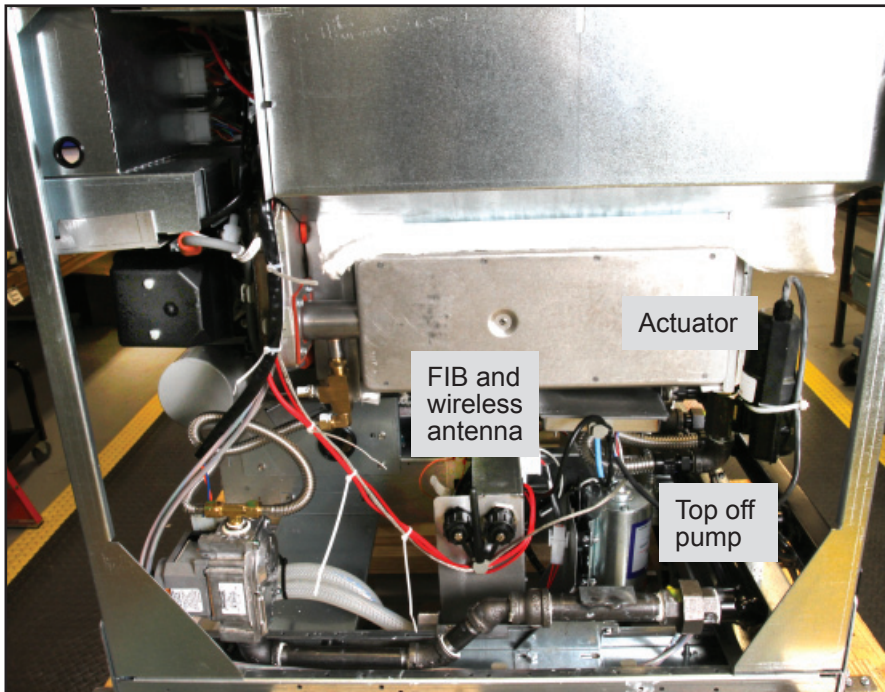

The FilterQuick fryer is built on a chassis that allows side removal for access to components. The screws securing the sides are in slotted holes (above). Loosen the screws and lift the side away. The right side is shown removed (left). The gas valve and the FIB box's antenna, LAN and USB ports are visible.

Touchscreen-Equipped Fryers

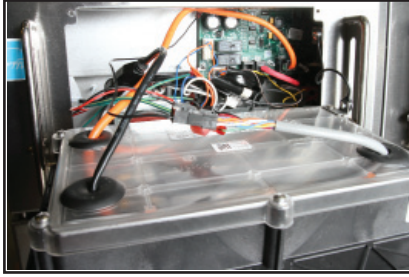

The controller is shown down from the control box (above). A lanyard protects it from falling. Directly below the control box on gas fryers, the ignition modules (right) are mounted horizontally in metal boxes.

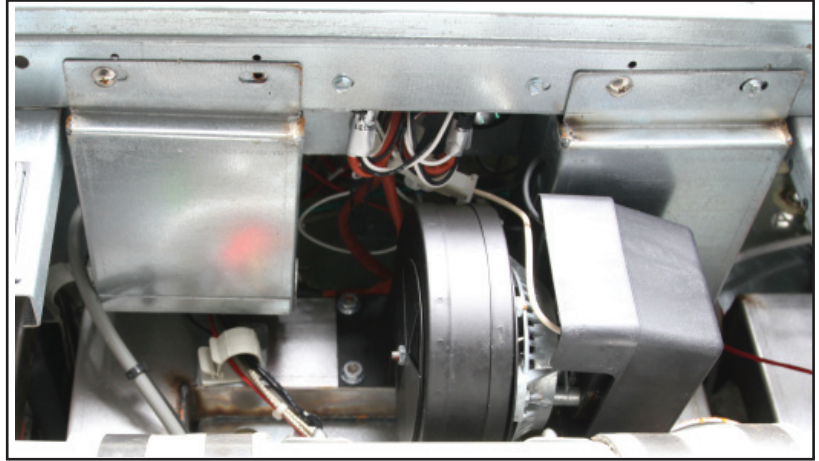

The Oil Quality Sensor is shown mounted adjacent to the filter pan in a FilterQuick fryer. Oil flows through the sensor after it leaves the filter pan. The device measures total polar material (TPM) during a filter cycle and projects the remaining life of the oil.



The USB slot (above left) is behind the left door of the fryer. It is used for software updates. The rocker switch below is for resetting the fryer. The orange button (right above) is behind the door in front of the JIB. It is for resetting the top off system after a JIB is replaced.

Touchscreen-Equipped Fryers

The FQ4000 Controller Introduces Fryer Connectivity

Data on the fryer's use is collected on the circuit boards, consolidated by the Smart Interface Board and passed over the bus to the SUI board, located in the Filter Interface Board box. Earlier versions of this communication system had the communication components in a separate box under the FIB.

The data are then transferred, via the store's wireless router or a cellular router, to an internet-based dash-

board hosted on a server. Store management can monitor oil usage, the frequency of the staff's response to filter requests, cook cycles and store-level fryer management. Successful communication from the fryer can be determined from the Software Version screen of the controller, where signal strength and the IP address can be seen (see below).

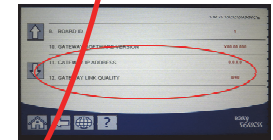
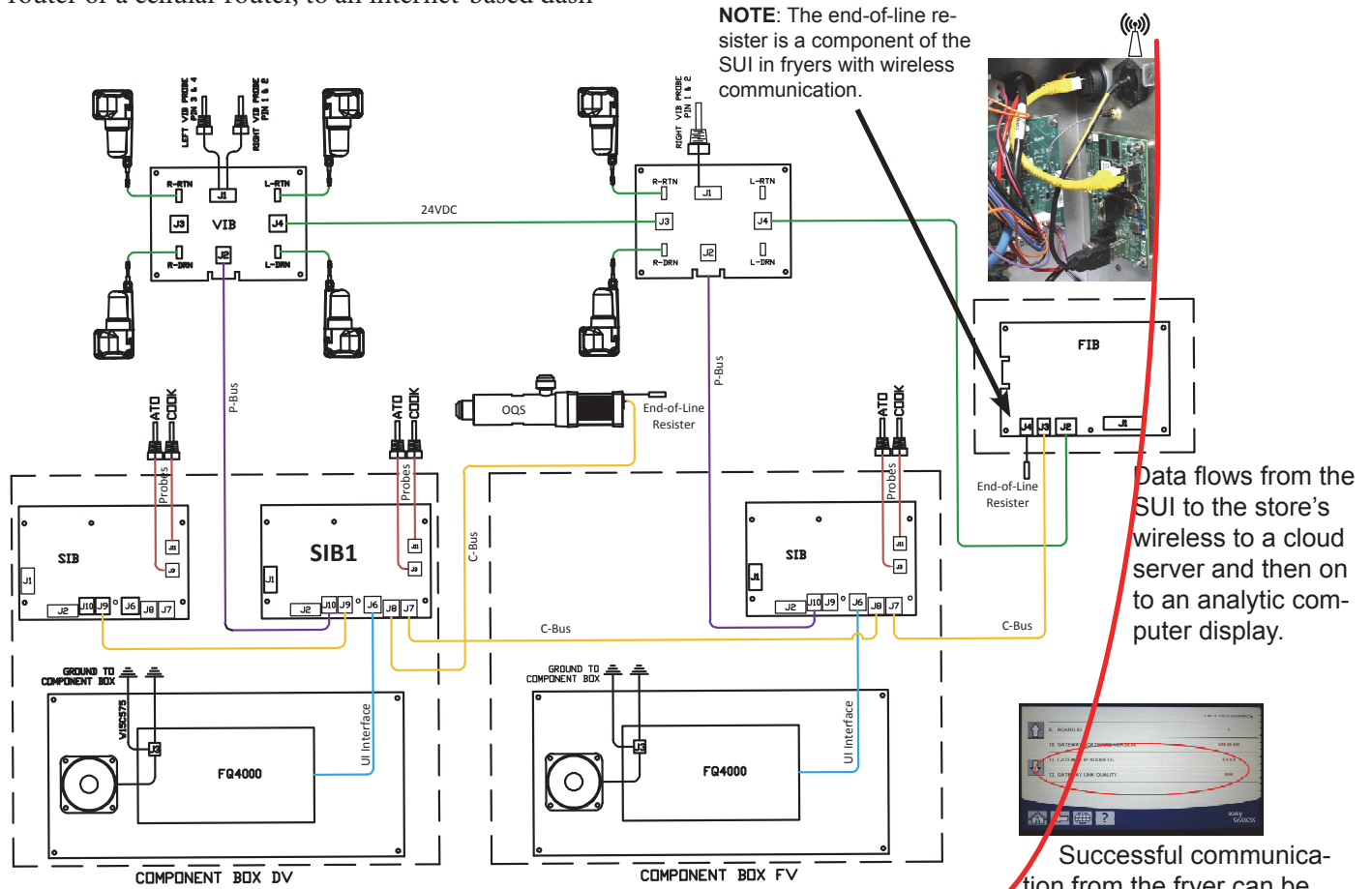

Successful communication from the fryer can be determined at the Software Version screen on the controller, where the signal strength and the IP address can be seen.

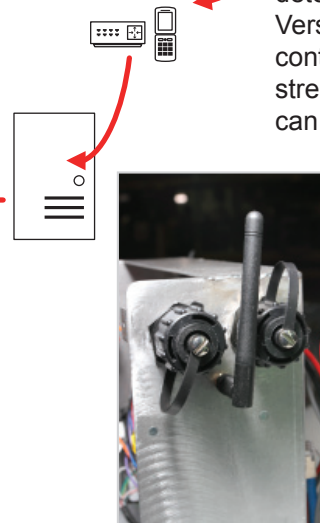

An antenna on the exterior of the FIB is the connection to the store's wireless. Caps on either side of the antenna provide access to LAN and USB ports.

Touchscreen-Equipped Fryers



FilterQuick with FQ4000 for Taco Bell



Cooking

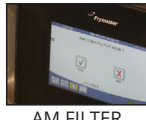

AM FILTER



PM FILTER



Changing JIB



Cleaning Inline Filter

Move a smart-phone with QR-scanning software over a QR-code to see a short video on a fryer operation. The videos can be accessed one at a time with the code or by scrolling the displayed menu when any are playing.

NOTE: QR-code readers are quick to react. Cover adjacent codes, if necessary, to ensure you open the video you want.

The complete playlist of videos specific to the FilterQuick with FQ4000 for Taco Bell is available at the site below.



Starting, Using Controller



Changing Products



Changing Menus



Preparing Filter Pan



Fryer's Friend Use





Touchscreen-Equipped Fryers





FilterQuick with FQ4000 Quick Reference



Cooking



Clean and Filter



Low JIB



Navigating Controller



Manual Top Off

Move a smartphone with QR-scanning software over a QR-code to see a short video on a fryer operation. The videos can be accessed one at a time with the codes or selected from the viewer menu when any of these are playing.

NOTE: QR code readers are sensitive, quick to react. Cover adjacent codes, if necessary, to ensure you open the video you want.

Other FilterQuick videos, such as in-line filter cleaning (below), can also be found on Frymaster's Channel.



Yes to Filter Now



Oil Quality Check



Filter Pan Prep



Changing Menus, Products



Energy Savings Mode



Chapter 4: Charts and Tables

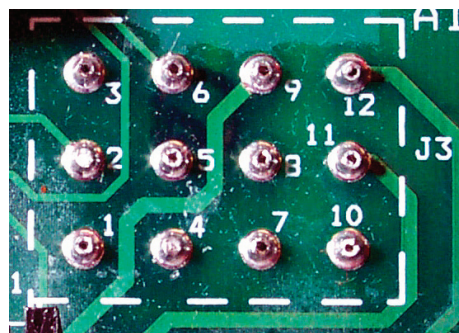
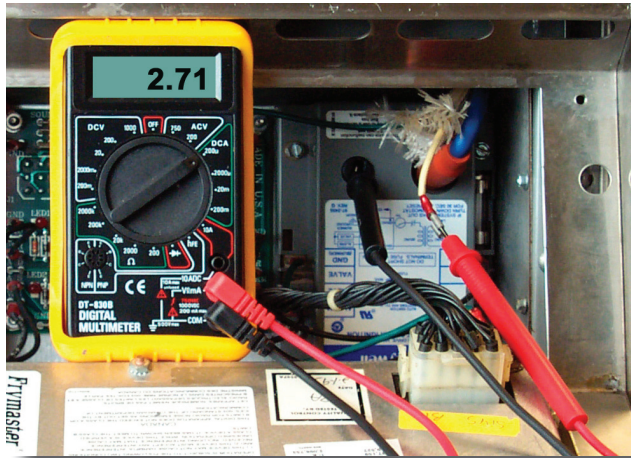

- Computer Codes
- Electrical Formulas
- Conversion Formulas
- Probe Resistance Charts
- Pressure Conversion Table
- Orifice Chart

Charts and Tables

BK 3 Lane		CM4-S	COMPUTER	FQ4000	
Recovery	1652	Recovery	1652	Menu	1650
Program	1650	Program	1650	Recipes	1650
F° to C°	1658	F° to C°	1658	Settings-Manager	1656
Set Up	1656	Set Up	1656	Settings-Service	3000
Constant Temp Display	1651	Manual Reset	1651	Service-Manager	1656
Boil Out	1653	Heads Cooked	1653	Service-Technician	3000
Manual Reset	3322	Cooked/Last Filter	1654	Component Check	9000
Language Choice	1655	Clear Head Counter	1657		
Sound Level	1655	Global Count	1658	M2000	
Total Cook Cycles	5000	Clear Filter Prompt	1111	Recovery	1652
Clear Total Cook Cycles	5005	Cancel Filter	1119	Program	1650
Set to Multi-Product	5050	UHC-HD		F° to C°	1658
Set to Dedicated	5060	Program	1955	Set Up	1656
Enable-Disable Melt Cycle	1751	F° to C°	1955	Manual Reset	3322
Enable-Disable Boil Out	1752	Set Up	1955	Language Choice	1655
		Load Software	98765	Sound Level	1655
K/F3000		View Software Version	090809	Hi-Limit Test L	8888
Recovery	0042	Update Language File	090709	Hi-Limit Test R	9999
Program	3228	Service Test Mode	1111		
Fahrenheit to Celsius	1658	Switch 6 to 3 Row	11111	M3000	
Set Up	3228	LON Works Test Pin	4557	Recovery	0042
Manual Reset	3322	Capture Menu	759248	Program	1234
Reset Usage	3228	CM3.5		F° to C°	1658
Tech Mode	1650	Recovery	1652	Set Up	1234
Domestic to Int'l Menu	1212	Program	1650	Manual Reset	3322
Reset Filter Stats	0469	F° to C°	1658	Manager Mode	4321
Reset BADCRC	9988	Set Up	1656	Reset Usage	4321
Reset Service Required	1111	Constant Temp Display	165L	Tech Mode	1650
Reset Call Tech	1000	Boil Out	1653	US to Int'l Menu	1212
Config Setup	7628	3000/FQ3000		Reset Filter Stats	0469
		Recovery	0042	Reset Call Tech	1000
KFC-1		Program	1650	Reset BADCRC	9988
Recovery	1652	Fahrenheit to Celsius	1658	Reset Service Required	1111
Program	1650	Set Up	1656	M4000	
F° to C°	1658	Reset Usage	1656	Menu	1234
Set Up	1656	Tech Mode	3000	Recipes	1234
Manual Reset	1651	Domestic to Int'l Menu	1212	Settings-Manager	1234
		Reset Filter Stats	0469	Settings-Service	1650
Wingstreet		Reset BADCRC	9988	Service -Manager	4321
Recovery	1652	Reset Service Required	1111	Service/Tech Mode-Tech	1650
Program	1650	Reset Call Tech	1000	Component Check	9000
F° to C°	1658	Config Setup	7628		
Set Up	1656	Reset Stats FQ3000	1656		
Manual Reset	3322	Reset Factory Menu	3322		
Setback Temp	1212				

NOTE: • 4000-series controllers have touchscreens. Codes access menus with multiple functions.
 • Some call-for-service resets require terminal plug removal and a power cycle.

Charts and Tables

Model Numbers

Example of gas H55 model. Characters in gray represent options, such as dual vats and basket lifts, which wouldn't appear in the model number if not present on the fryer.

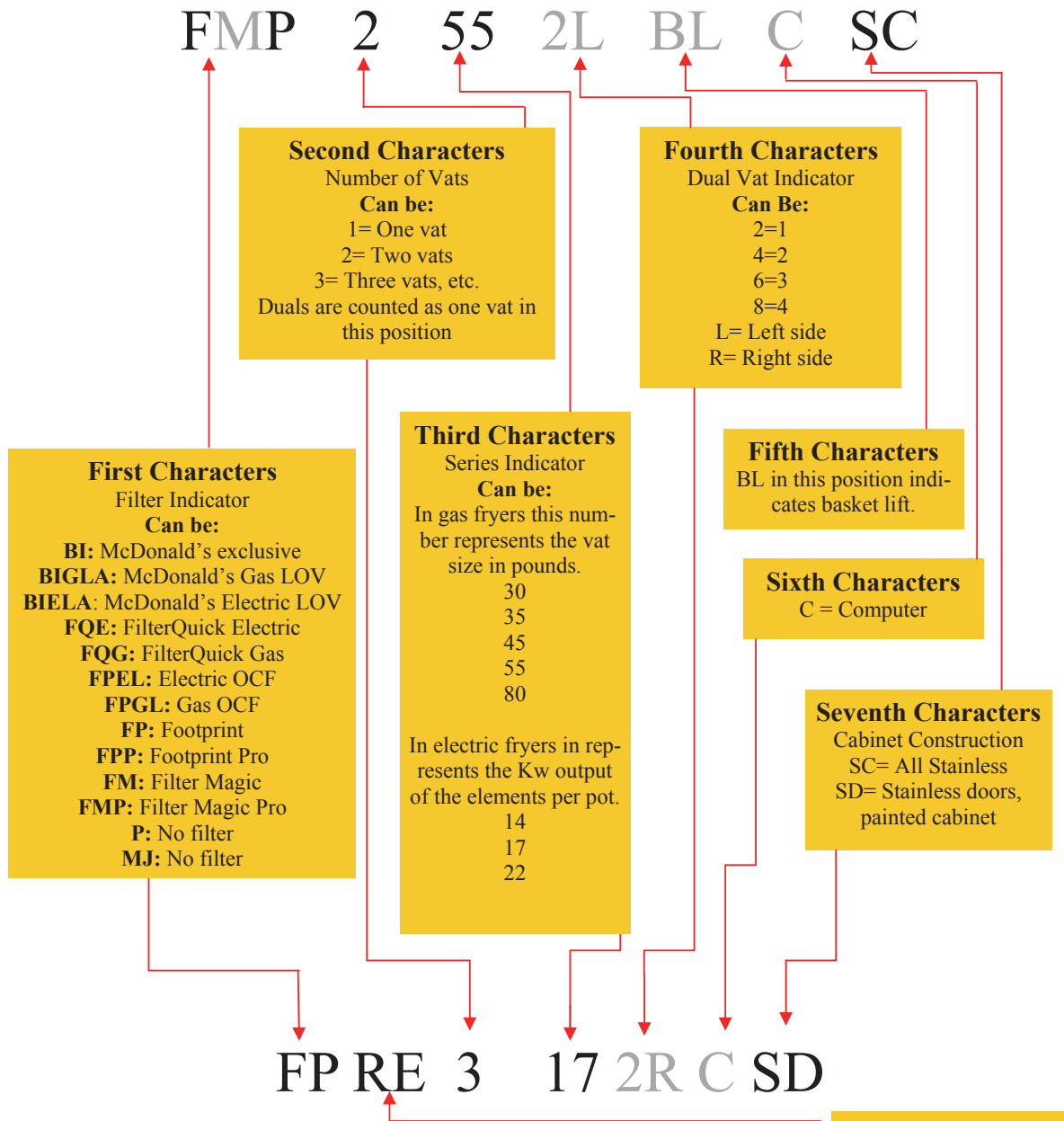

Example of an electric model. Characters in gray represent options, such as dual vats and basket lifts, which wouldn't appear in the model number if not present on the fryer.

Charts and Tables

Reading Model Numbers

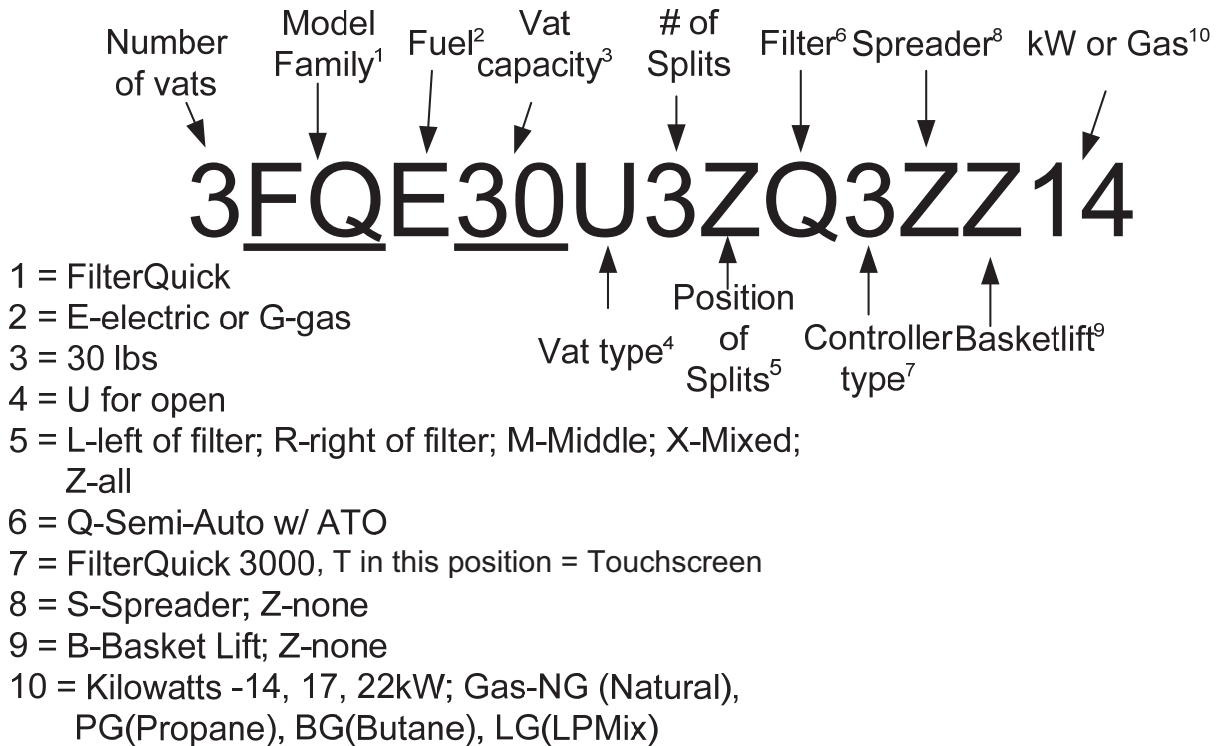

Charts and Tables
Electrical Formulas

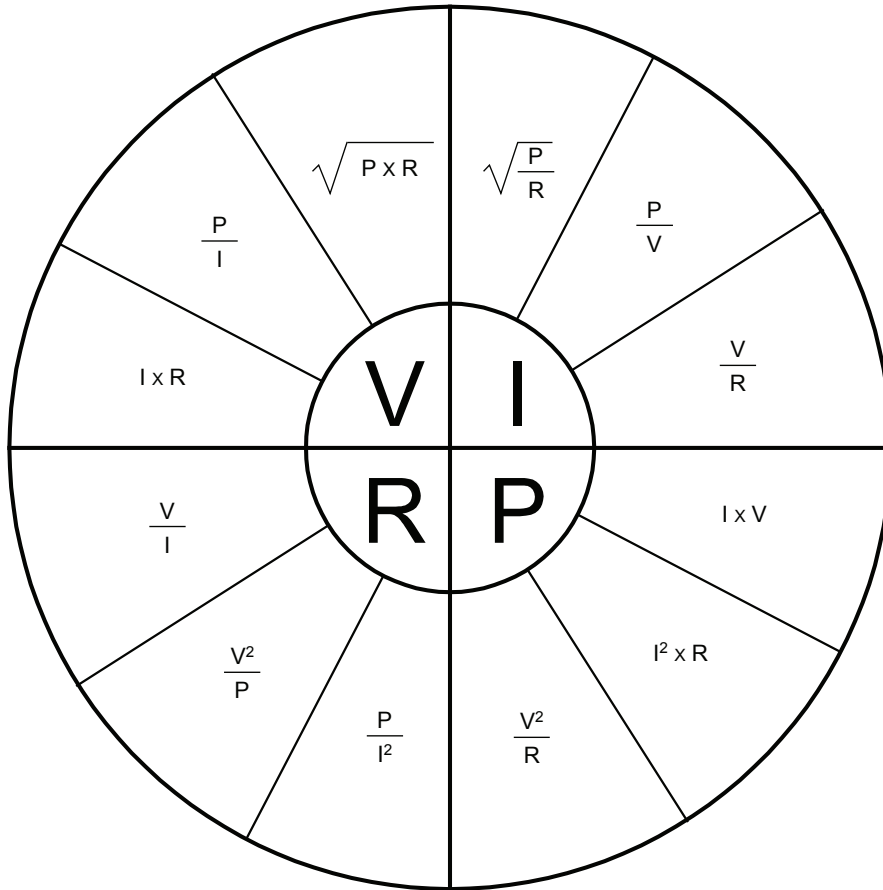

V = Voltage (Volts)
I = Current (Amps)
R = Resistance (Ohms)
P = Power (Watts)

MICRO = 1/1,000,000 (one millionth) e.g., microamps
MILLI = 1/1,000 (one thousandth) e.g., millivolts
KILO = 1000 X (one thousand times) e.g., kilowatts
MEGA = 1,000,000 X (one million times) e.g., megohms

Charts and Tables

Pressure Conversion Table

Inches H ₂ O	PSI	Inches Hg	mm Hg	bar	mbar	Pa	kPA
1	0.036	0.073	1.868	0.002	2.488	248.827	0.249
2	0.072	0.147	3.735	0.005	4.977	497.654	0.498
3	0.108	0.220	5.603	0.007	7.465	746.481	0.746
4	0.144	0.294	7.470	0.010	9.953	995.309	0.995
5	0.180	0.367	9.338	0.012	12.441	1244.136	1.244
6	0.217	0.441	11.205	0.015	14.930	1492.963	1.493
7	0.253	0.514	13.073	0.017	17.418	1741.790	1.742
8	0.289	0.588	14.940	0.020	19.906	1990.617	1.991
9	0.325	0.661	16.808	0.022	22.394	2239.444	2.239
10	0.361	0.735	18.676	0.025	24.883	2488.271	2.488
11	0.397	0.808	20.543	0.027	27.371	2737.099	2.737
12	0.433	0.882	22.411	0.030	29.859	2985.926	2.986
13	0.469	0.955	24.278	0.032	32.348	3234.753	3.235
14	0.505	1.029	26.146	0.035	34.836	3483.580	3.484
15	0.541	1.102	28.013	0.037	37.324	3732.407	3.732
16	0.577	1.176	29.881	0.040	39.812	3981.234	3.981
17	0.613	1.249	31.748	0.042	42.301	4230.061	4.230
18	0.650	1.323	33.616	0.045	44.789	4478.888	4.479
19	0.686	1.396	35.484	0.047	47.277	4727.716	4.728
20	0.722	1.470	37.351	0.050	49.765	4976.543	4.977
21	0.758	1.543	39.219	0.052	52.254	5225.370	5.225
22	0.794	1.616	41.086	0.055	54.742	5474.197	5.474
23	0.830	1.690	42.954	0.057	57.230	5723.024	5.723
24	0.866	1.763	44.821	0.060	59.719	5971.851	5.972
25	0.902	1.837	46.689	0.062	62.207	6220.678	6.221
26	0.938	1.910	48.556	0.065	64.695	6469.506	6.470
27	0.974	1.984	50.424	0.067	67.183	6718.333	6.718
28	1.010	2.057	52.292	0.070	69.672	6967.160	6.967

Conversion Formulas
PSI = Inches H ₂ O/27.71
PSI x 27.71 = Inches H ₂ O
PSI x 2.036 = Inches Hg
PSI x 51.74 = Millimeters of Hg
PSI x .0689 = Bars
PSI x 68.95 = Millibars
PSI x 6895 = Pa
PSI x 6.895 = kPa

Charts and Tables

Orifice Chart for Common Models

Model	Gas Type	BTUs	Manifold Gas Pressure (Inches H₂O)	Orifice Size (Drill/mm)	Part Number
J1C-MJ15	Natural	45,000	4	55/1.30	810-0131
	Propane	45,000	11	67/.81	810-0140
	Butane	45,000	11	68/.79	810-0141
35 Series	Natural	110,000	4	51/1.70	810-0129
	Propane	110,000	9	59/1.05	810-0134
45 Series	Natural	122,000	3.5	53/1.45	810-0315
	Propane	122,000	8.25	65/.86	810-0340
47 Series	Natural	122,000	3.5	53/1.45	826-1357
	Propane	122,000	8.25	65/.86	826-1387
CF/J3C Series	Natural	150,000	3.5	54/1.40	810-0330
	Propane	150,000	8.25	65/.86	810-0340
G18-G24FB/FBR	Natural	90,000	4	30/3.26	810-0916
	Propane	90,000	11	47/2.00	810-0917
GF14 Series	Natural	100,000	4	52/1.65	810-0496
	Propane	100,000	10	59/1.05	810-0134
GF40 Series	Natural	122,000	3.5	53/1.45	810-0315
	Propane	122,000	8.25	65/.86	810-0340
H50/H52 Series	Natural	80,000	3	29/3.40	810-0403
	Propane	80,000	8.25	44/2.10	810-0386
TCF Series	Natural	112,000	4	44/2.18	810-0675
	Propane	112,000	11	54/1.40	810-0710
OCF Series	Natural	75,000	6	30/3.26	810-3861
	Propane	75,000	11	45/2.05	810-3860
LOV	Natural	75,000	6	30/3.26	810-3861
	Propane	75,000	11	45/2.05	810-3860
FilterQuick Series	Natural	75,000	6	30/3.26	810-3861
	Propane	75,000	11	45/2.05	810-3860
LOV/FQ/OCF	Natural	70,000	3.2	31/3.18	810-3864
	Propane	70,000	8.25	48/1.95	810-3865

Charts and Tables

Probe Resistance Charts

<i>Probe Resistance Chart</i>																	
<i>For use with Minco or Hycal Thermistor Probes only (fryer equipped).</i>																	
<i>Not for use with Spaghetti Magic System Probes.</i>																	
F	OHMS	C	F	OHMS	C	F	OHMS	C	F	OHMS	C	F	OHMS	C	F	OHMS	C
32	1000	0	83	1107	28	134	1214	57	185	1320	85	236	1424	113			
33	1002	1	84	1110	29	135	1216	57	186	1322	86	237	1426	114			
34	1004	1	85	1112	29	136	1218	58	187	1324	86	238	1428	114			
35	1006	2	86	1114	30	137	1220	58	188	1326	87	239	1430	115			
36	1008	2	87	1116	31	138	1222	59	189	1328	87	240	1432	116			
37	1011	3	88	1118	31	139	1224	59	190	1330	88	241	1434	116			
38	1013	3	89	1120	32	140	1226	60	191	1332	88	242	1436	117			
39	1015	4	90	1122	32	141	1229	61	192	1334	89	243	1438	117			
40	1017	4	91	1124	33	142	1231	61	193	1336	89	244	1440	118			
41	1019	5	92	1126	33	143	1233	62	194	1338	90	245	1442	118			
42	1021	6	93	1128	34	144	1235	62	195	1340	91	246	1444	119			
43	1023	6	94	1131	34	145	1237	63	196	1342	91	247	1447	119			
44	1025	7	95	1133	35	146	1239	63	197	1344	92	248	1449	120			
45	1030	7	96	1135	36	147	1241	64	198	1346	92	249	1451	121			
46	1032	8	97	1137	36	148	1243	64	199	1348	93	250	1453	121			
47	1034	8	98	1139	37	149	1245	65	200	1350	93	251	1455	122			
48	1036	9	99	1141	37	150	1247	66	201	1352	94	252	1457	122			
49	1038	9	100	1143	38	151	1249	66	202	1354	94	253	1459	123			
50	1040	10	101	1145	38	152	1251	67	203	1357	95	254	1461	123			
51	1042	11	102	1147	39	153	1253	67	204	1359	96	255	1463	124			
52	1044	11	103	1149	39	154	1255	68	205	1361	96	256	1465	124			
53	1046	12	104	1151	40	155	1258	68	206	1363	97	257	1467	125			
54	1049	12	105	1154	41	156	1260	69	207	1365	97	258	1469	126			
55	1051	13	106	1156	41	157	1262	69	208	1367	98	259	1471	126			
56	1053	13	107	1158	42	158	1264	70	209	1369	98	260	1473	127			
57	1055	14	108	1160	42	159	1266	71	210	1371	99	261	1475	127			
58	1057	14	109	1162	43	160	1268	71	211	1373	99	262	1477	128			
59	1059	15	110	1164	43	161	1270	72	212	1375	100	263	1479	128			
60	1061	16	111	1166	44	162	1272	72	213	1377	101	264	1481	129			
61	1063	16	112	1168	44	163	1274	73	214	1379	101	265	1483	129			
62	1065	17	113	1170	45	164	1276	73	215	1381	102	266	1485	130			
63	1067	17	114	1172	46	165	1278	74	216	1383	102	267	1487	131			
64	1068	18	115	1174	46	166	1280	74	217	1385	103	268	1489	131			
65	1070	18	116	1176	47	167	1282	75	218	1387	103	269	1491	132			
66	1072	19	117	1179	47	168	1284	76	219	1389	104	270	1493	132			
67	1074	19	118	1181	48	169	1287	76	220	1391	104	271	1495	133			
68	1076	20	119	1183	48	170	1289	77	221	1393	105	272	1497	133			
69	1078	21	120	1185	49	171	1291	77	222	1395	106	273	1499	134			
70	1080	21	121	1187	49	172	1293	78	223	1398	106	274	1501	134			
71	1082	22	122	1189	50	173	1295	78	224	1400	107	275	1503	135			
72	1084	22	123	1191	51	174	1297	79	225	1402	107	276	1505	136			
73	1086	23	124	1193	51	175	1299	79	226	1404	108	277	1507	136			
74	1089	23	125	1195	52	176	1301	80	227	1406	108	278	1509	137			
75	1091	24	126	1197	52	177	1303	81	228	1408	109	279	1512	137			
76	1093	24	127	1199	53	178	1305	81	229	1410	109	280	1514	138			
77	1095	25	128	1201	53	179	1307	82	230	1412	110	281	1516	138			
78	1097	26	129	1204	54	180	1309	82	231	1414	111	282	1518	139			
79	1099	26	130	1206	54	181	1311	83	232	1416	111	283	1520	139			
80	1101	27	131	1208	55	182	1313	83	233	1418	112	284	1522	140			
81	1103	27	132	1210	56	183	1315	84	234	1420	112	285	1524	141			
82	1105	28	133	1212	56	184	1317	84	235	1422	113	286	1526	141			

Charts and Tables

Probe Resistance Chart (cont.)

For use with Minco or Hycal Thermistor Probes only (fryer equipped).

Not for use with Spaghetti Magic System Probes.

F	OHMS	C	F	OHMS	C	F	OHMS	C	F	OHMS	C	F	OHMS	C
287	1528	142	338	1630	170	389	1732	198	440	1833	227	491	1932	255
288	1530	142	339	1632	171	390	1734	199	441	1835	227	492	1934	256
289	1532	143	340	1634	171	391	1736	199	442	1837	228	493	1936	256
290	1534	143	341	1636	172	392	1738	200	443	1839	228	494	1938	257
291	1536	144	342	1638	172	393	1740	201	444	1841	229	495	1940	257
292	1538	144	343	1640	173	394	1742	201	445	1843	229	496	1942	258
293	1540	145	344	1642	173	395	1744	202	446	1845	230	497	1944	258
294	1542	146	345	1644	174	396	1746	202	447	1846	231	498	1946	259
295	1544	146	346	1646	174	397	1748	203	448	1848	231	499	1948	259
296	1546	147	347	1648	175	398	1750	203	449	1850	232	500	1950	260
297	1548	147	348	1650	176	399	1752	204	450	1852	232	501	1952	261
298	1550	148	349	1652	176	400	1754	204	451	1854	233	502	1954	261
299	1552	148	350	1654	177	401	1756	205	452	1856	233	503	1956	262
300	1554	149	351	1656	177	402	1758	206	453	1858	234	504	1958	262
301	1556	149	352	1658	178	403	1760	206	454	1860	234	505	1960	263
302	1558	150	353	1660	178	404	1762	207	455	1862	235	506	1962	263
303	1560	151	354	1662	179	405	1764	207	456	1864	236	507	1964	264
304	1562	151	355	1664	179	406	1766	208	457	1866	236	508	1965	264
305	1564	152	356	1666	180	407	1768	208	458	1868	237	509	1967	265
306	1566	152	357	1668	181	408	1770	209	459	1870	237	510	1969	266
307	1568	153	358	1670	181	409	1772	209	460	1872	238	511	1971	266
308	1570	153	359	1672	182	410	1774	210	461	1874	238	512	1973	267
309	1572	154	360	1674	182	411	1776	211	462	1876	239	513	1975	267
310	1574	154	361	1676	183	412	1778	211	463	1878	239	514	1977	268
311	1576	155	362	1678	183	413	1780	212	464	1880	240	515	1979	268
312	1578	156	363	1680	184	414	1781	212	465	1882	241	516	1981	269
313	1580	156	364	1682	184	415	1783	213	466	1884	241	517	1983	269
314	1582	157	365	1684	185	416	1785	213	467	1886	242	518	1985	270
315	1584	157	366	1686	186	417	1787	214	468	1888	242	519	1987	271
316	1586	158	367	1688	186	418	1789	214	469	1890	243	520	1989	271
317	1588	158	368	1690	187	419	1791	215	470	1892	243	521	1991	272
318	1590	159	369	1692	187	420	1793	216	471	1893	244	522	1993	272
319	1592	159	370	1694	188	421	1795	216	472	1895	244	523	1995	273
320	1594	160	371	1696	188	422	1797	217	473	1897	245	524	1996	273
321	1596	161	372	1698	189	423	1799	217	474	1899	246	525	1998	274
322	1598	161	373	1700	189	424	1801	218	475	1901	246	526	2000	274
323	1600	162	374	1702	190	425	1803	218	476	1903	247	527	2002	275
324	1602	162	375	1704	191	426	1805	219	477	1905	247	528	2004	276
325	1604	163	376	1706	191	427	1807	219	478	1907	248	529	2006	276
326	1606	163	377	1708	192	428	1809	220	479	1909	248	530	2008	277
327	1608	164	378	1710	192	429	1811	221	480	1911	249	531	2010	277
328	1610	164	379	1712	193	430	1813	221	481	1913	249	532	2012	278
329	1612	165	380	1714	193	431	1815	222	482	1915	250	533	2014	278
330	1614	166	381	1716	194	432	1817	222	483	1917	251	534	2016	279
331	1616	166	382	1718	194	433	1819	223	484	1919	251	535	2018	279
332	1618	167	383	1720	195	434	1821	223	485	1921	252	536	2020	280
333	1620	167	384	1722	196	435	1823	224	486	1923	252	537	2022	281
334	1622	168	385	1724	196	436	1825	224	487	1925	253	538	2025	281
335	1624	168	386	1726	197	437	1827	225	488	1927	253	539	2027	282
336	1626	169	387	1728	197	438	1829	226	489	1929	254	540	2029	282
337	1628	169	388	1730	198	439	1831	226	490	1931	254	541	2031	283

Charts and Tables

UHC RTD Probe Resistance Chart

All Cabinets: UHC, UHC-P, UHC-HD

Sensor Temp (°F)	R Sensor	Sensor Temp (°C)
55	104.984	12.77
60	106.065	15.55
65	107.145	18.33
70	108.224	21.11
75	109.302	23.88
80	110.380	26.66
85	111.456	29.44
90	112.532	32.22
95	113.606	35.00
100	114.680	37.77
105	115.753	40.55
110	116.825	43.33
115	117.896	46.11
120	118.966	48.88
125	120.036	51.66
130	121.104	54.44
135	122.172	57.22
140	123.239	60.00
145	124.304	62.77
150	125.369	65.55
155	126.433	68.33
160	127.496	71.11
165	128.559	73.88
170	129.620	76.66
175	130.680	79.44
180	131.740	82.22
185	132.799	85.00
190	133.856	87.77
195	134.913	90.55
200	135.969	93.33
205	137.024	96.11
210	138.078	98.88
215	139.132	101.66
220	140.184	104.44
225	141.235	107.22
230	142.286	110.00
235	143.336	112.77
240	144.385	115.55
245	145.433	118.33
250	146.480	121.11
255	147.526	123.88
260	148.570	126.66

Charts and Tables

Dean Thermatron® Probe Resistance Charts

Below are resistance charts applicable to Dean fryers equipped with Thermatron® controllers.

Electronic Thermostat Systems (Probe wire color: Two Black Wires or Two Brown Wires)		
° Celsius	° Fahrenheit	Ohms (± 3%)
21	70	108130
27	80	84606
32	90	66721
38	100	53020
43	110	42452
49	120	34206
54	130	27735
60	140	22641
66	150	18588
71	160	15349
77	170	12741
82	180	10635
88	190	8925
93	200	7527
99	210	6391
104	220	5470
110	230	4705
116	240	4030
121	250	3441
127	260	2967
132	270	2583
138	280	2255
143	290	1977
149	300	1729
154	310	1496
160	320	1320
166	330	1170
171	340	1051
177	350	942
182	360	840
188	370	750
193	380	676
199	390	605
204	400	541



FRYMASTER
8700 LINE AVENUE, SHREVEPORT, LA 71106-6800

800-551-8633
318-865-1711
WWW.FRYMASTER.COM
EMAIL: FRYSERVICE@WELBILT.COM



WELBILT

Bringing innovation to the table

WWW.WELBILT.COM

Welbilt provides the world's top chefs, and premier chain operators or growing independents with industry leading equipment and solutions. Our cutting-edge designs and lean manufacturing tactics are powered by deep knowledge, operator insights, and culinary expertise. All of our products are backed by KitchenCare® – our aftermarket, repair, and parts service.

- CLEVELAND
- DELFIELD®
- FRYMASTER®
- KOLPAK®
- MANITOWOC®
- MERRYCHEF®
- CONVOTHERM®
- FITKITCHEN™
- GARLAND
- LINCOLN
- MERCÓ®
- MULTIPLEX®